

Fixed Displacement Plug-In Motor A2FE

RE 91008/03.97
replaces 04.96

for open and closed circuits

Sizes 28...355
Series 6
Nom. Pressure up to 400 bar
Peak Pressure up to 450 bar

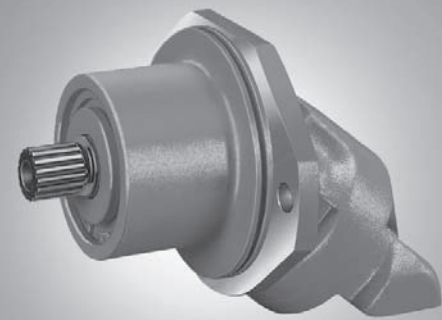

Contents

Features	1
Ordering Code	2
Technical Data	3...5
Preferred types	5
Unit Dimension, Sizes 28...180	6
Unit Dimensions, Size 250, 355	7
Port plate 17, 18, 19	8

Features

- The fixed displacement plug-in motor A2FE is equipped with a standard axial tapered piston rotary group of bent axis design.
- Hydrostatic plug-in motors are intended primarily for installation in mechanical gearboxes, e.g. track drive gear boxes.
- The design of the motor with the mounting flange in the centre of the housing allows it to be almost fully integrated into a mechanical gearbox to give an extremely compact unit.
- complete unit, ready assembled and tested
 - easy assembly,
 simply «plugs-in» to mechanical gearboxes
 - no installation tolerances to consider

Ordering Code / Standard Program

	A2F		E		/	6		W	-										
--	-----	--	---	--	---	---	--	---	---	--	--	--	--	--	--	--	--	--	--

Hydraulic Fluid

Mineral oil (no code)		
HF-fluids	sizes 28...180 (no code)	
	size 250...355 ¹⁾	E-

Axial piston unit

Bent axis design, fixed displacement	A2F
--------------------------------------	-----

Drive shaft bearings

	28...180	250...355	
mechanical bearings (no code)	●	●	
Long-Life bearings	—	●	L

Mode of operation

Plug-in motor	E
---------------	---

Size

≥ Displacement V _g (cm ³)	28	32	45	56	63	80	90	107	125	160	180	250	355
--	----	----	----	----	----	----	----	-----	-----	-----	-----	-----	-----

Sizes 28...180: production plant Elchingen; Sizes 250...355: production plant Horb

Series

	6
--	---

Index

	sizes 28...180	1
	size 250...355	0

Direction of rotation

viewed on shaft end	alternating	W
---------------------	-------------	---

Seals

	28...180	250...355	
NBR (nitril-caoutchouc), shaft seal in FPM	●	—	N
FPM (fluor-caoutchouc)	●	●	V

Shaft end

	28	32	45	56	63	80	90	107	125	160	180	250	355	
Splined shaft end	●	●	●	●	●	●	●	●	●	●	●	—	—	A
	●	—	●	●	●	●	●	●	●	●	●	●	●	Z

Mounting flange

	28...180	250...355	
Special 2-hole flange	●	—	L
Special 4-hole flange	—	●	M

Service line connections

			28	32	45	56	63	80	90	107	125	160	180	250	355	
Ports A and B SAE, rear end	01	0	●	●	●	●	●	●	●	●	●	●	●	●	—	010
Ports A and B SAE at side, same side (metr. mounting threads)	10	0	●	●	●	●	●	●	●	●	●	●	●	—	●	100
		6	●	●	●	●	●	●	●	—	—	—	—	—	—	106
port plate with integrated pressure relief valves, for mounting a motion control valve	17	1	—	—	—	—	—	—	—	●	●	—	—	—	—	171
port plate with integrated pressure relief valves, for mounting a motion control valve	18	1	●	●	●	●	●	●	●	●	●	●	●	—	—	181
port plate with integrated pressure relief valves	19	1	●	●	●	●	●	●	●	●	●	●	●	—	—	191
		2	●	●	●	●	●	●	●	●	●	●	●	—	—	192

Valves

without valves (no code)	0
with pressure relief valves (<i>without</i> pressure sequence range)	1
with pressure relief valves (<i>with</i> pressure sequence range)	2
with integrated flushing valve	6

● = available
— = not available

■ = preferred program (preferred types see page 5)

¹⁾ only in connection with drive shaft bearings "L"

Technical Data

Fluid

We request that before starting a project detailed information about the choice of pressure fluids and application conditions are taken from our catalogue sheets RE 90220 (mineral oil), RE 90221 (environmentally acceptable hydraulic fluids) and RE 90223 (fire resistance fluids, HF).

When using HF- or environmentally acceptable hydraulic fluids possible limitations for the technical data have to be taken into consideration. If necessary please consult our technical department (please indicate type of the hydraulic fluid used for your application on the order sheet).

Operating viscosity range

In order to obtain optimum efficiency and service life, we recommend that the operating viscosity (at operating temperature) be selected from within the range:

$$v_{\text{opt}} = \text{operating viscosity } 16 \dots 36 \text{ mm}^2/\text{s}$$

referred to the loop temperature (closed circuit) or tank temperature (open circuit).

Viscosity limits

The limiting values for viscosity are as follows:

sizes 28...180

$$v_{\text{min}} = 5 \text{ mm}^2/\text{s},$$

short term at a max. permissible temperature of $t_{\text{max}} = 115^\circ\text{C}$

$$v_{\text{max}} = 1600 \text{ mm}^2/\text{s}, \text{ short term on cold start } (t_{\text{min}} = -40^\circ\text{C})$$

sizes 250...355

$$v_{\text{min}} = 10 \text{ mm}^2/\text{s}$$

short term at a max. permissible leakage oil temp. of $t_{\text{max}} = 90^\circ\text{C}$

$$v_{\text{max}} = 1000 \text{ mm}^2/\text{s},$$

short term on cold start ($t_{\text{min}} = -25^\circ\text{C}$)

Please note that the max. fluid temperature is also not exceeded in certain areas (for instance bearing area).

At temperatures of -25°C up to -40°C special measures may be required for certain installation positions. Please contact us for further information.

Selection diagram

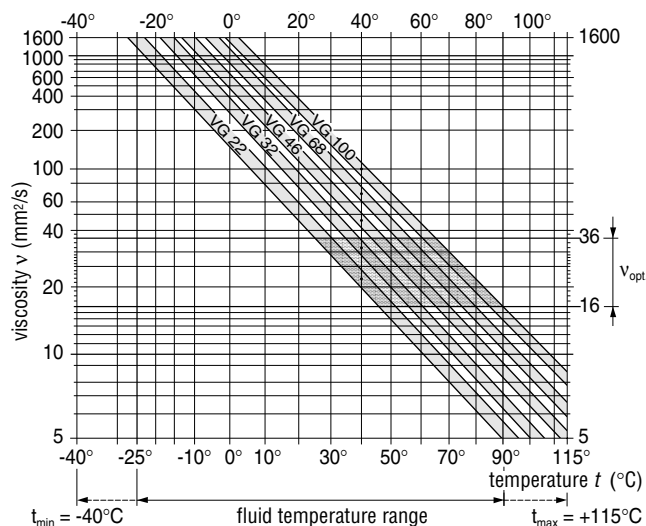

Notes on the selection of the hydraulic fluid

In order to select the correct fluid, it is necessary to know the operating temperature in the loop (closed circuit) or the tank temperature (open circuit) in relation to the ambient temperature. The hydraulic fluid should be selected so that within the operating temperature range, the operating viscosity lies within the optimum range (v_{opt}) (see shaded section of the selection diagram). We recommend that the highest possible viscosity range should be chosen in each case.

Example: At an ambient temperature of $X^\circ\text{C}$ the operating temperature (closed circuit: loop temperature; open circuit: tank temperature) is 60°C . Within the operating viscosity range (v_{opt} ; shaded area), this corresponds to viscosity ranges VG 46 or VG 68. VG 68 should be selected.

Important: The leakage oil (case drain oil) temperature is influenced by pressure and motor speed and is always higher than the circuit or tank temperature. However, at no point in the circuit may the temperature exceed 115°C for sizes 28...180 or 90°C for size 250...355.

If it is not possible to comply with the above conditions because of extreme operating parameters or high ambient temperatures please consult us.

Filtration

The finer the filtration the better the achieved purity grade of the pressure fluid and the longer the life of the axial piston unit.

To ensure the functioning of the axial piston unit a minimum purity grade of:

9 to NAS 1638

6 to SAE

18/15 to ISO/DIS 4406 is necessary.

At very high temperatures of the hydraulic fluid (90°C to max. 115°C , not permissible for sizes 250...355!) at least cleanliness

class 8 to NAS 1638

5 to SAE

17/14 to ISO/DIS 4406 is necessary.

If above mentioned grades cannot be maintained please consult supplier.

Direction of Flow

Clockwise rotation

Anti-clockwise rotation

A to B

B to A

Speed range

There is no limitation on minimum speed n_{min} . If uniformity of rotation is required, however, speed n_{min} should not be allowed to fall below 50 rpm.

See table on page 5 for max. permissible speeds.

Installation position

Any installation position possible. In case of vertical installation (drive shaft up) please contact us. The motor housing must be filled with fluid prior the commissioning, and must remain full whenever it is operating.

For extensive information on installation position, please consult our data sheet RE 90270 before completing your design work.

Symbol

Connections

A, B service line ports

T case drain port

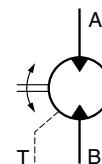

Technical Data

Operating pressure range

Maximum pressure at port A or B
(Pressure data to DIN 24312)

Sizes 28...180	Shaft end A		Shaft end Z *)
	sizes 28...180	sizes 28,45,56	sizes 63,90 80,107,160 125,180
Nominal pressure p_N	400 bar	400 bar	350 bar
Peak pressure p_{max}	450 bar	450 bar	400 bar

*) Attention: shaft end Z with drives of radial force loads at the drive shaft (pinion V-belt drives) necessitate reduction of the nominal pressure (please contact us).

Sizes 250...355

Nominal pressure p_N	350 bar
Peak pressure p_{max}	400 bar

With pulsating loads above 315 bar we recommend using the model with splined shaft, standart version A (sizes 28...180).

The summ of the pressures at ports A and B may not exceed 700 bar.

Case drain pressure

The lower the speed and the case drain pressure the higher the life expectancy of the shaft seal ring.

Shaft seal ring **FPM** (fluor-caoutchouc)

The values shown in the diagram are permissible loads of the seal ring and shall not be exceeded.

At stationary pressure loads in the range of the max. admissible leakage pressure a reduction of the life experience of the seal ring will result.

For a short period ($t < 5$ min.) for the sizes 28...180 pressure loads up to 5 bar independent from rotational speeds are permissible.

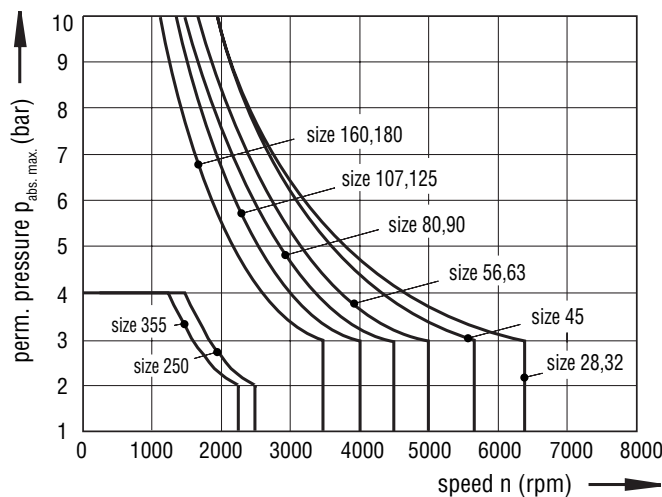

Special operation conditions may require limitations of these values.

Note:

- maximum permissible motor speeds are given in the table on page 5
- max. perm. casing pressure $p_{abs,max}$ — 10 bar (sizes 28...180)
— 4 bar (sizes 250...355)
- the pressure in the housing must be the same as or greater than the external pressure on the shaft seal.

Integral flushing valve

In order to prevent excessive heat build-up in closed circuit operation, it is possible to fit a flushing valve (built into the port plate).

- switching pressure $\Delta p \geq 8$ bar (this value is lower than the starting pressure of an unloaded motor).
- closed in centre position ($\Delta p < 8$ bar).

Sizes	23-32	45-63	80-90
Flushing-volume l/min	2,5	3,1	4,1

(values given for low pressure $\Delta p = 25$ bar)

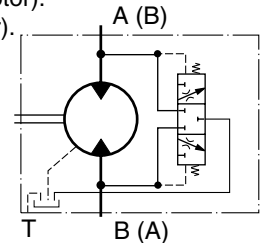

Long-Life bearings (L) (sizes 250... 355)

(for high life expectancy and use of HF-fluids)

The outer dimensions of the axial piston motors are identical to standard design (without long life bearings). The change from standard design to long life bearing system is possible.

Table of values (theoretical values, without considering η_{mh} and η_v ; values rounded)

Size			28	32	45	56	63	80	90	107	125	160	180	250	355
Displacement	V_g	cm ³	28,1	32,0	45,6	56,1	63,0	80,4	90,0	106,7	125,0	160,4	180,0	250	355
Max. speed	n_{max}	rpm	6300	6300	5600	5000	5000	4500	4500	4000	4000	3600	3600	2500	2240
	$n_{max\ interm.}^{1)}$	rpm	6900	6900	6200	5500	5500	5000	5000	4400	4400	4000	4000	–	–
Max. flow	q_{Vmax}	L/min	176	201	255	280	315	360	405	427	500	577	648	625	795
Torque constants	T_K	Nm/bar	0,445	0,509	0,725	0,89	1,0	1,27	1,43	1,70	1,99	2,54	2,86	3,98	5,64
Torque, $\Delta p = 400$ bar	T	Nm	178	204	290	356	400	508	572	680	796	1016	1144	1393 ²⁾	1976 ²⁾
Case volume		L	0,20	0,20	0,33	0,45	0,45	0,55	0,55	0,8	0,8	1,1	1,1	2,5	3,5
Moment of inertia	J	kgm ²	0,0012	0,0012	0,0024	0,0042	0,0042	0,0072	0,0072	0,0116	0,0116	0,0220	0,0220	0,061	0,102
Weight (approx.)	m	kg	10,5	10,5	15	18	19	23	25	34	36	47	48	82	110

¹⁾ Intermittent max. speed: overspeed at discharge and overtaking travel operations, $t < 5$ sec. and $\Delta p < 150$ bar

²⁾ $\Delta p = 350$ bar

Calculation of size

Flow	$q_v = \frac{V_g \cdot n}{1000 \cdot \eta_v}$	in L/min	$V_g =$ geometric displacement per rev.	in cm ³
			$T =$ torque	in Nm
Output speed	$n = \frac{q_v \cdot 1000 \cdot \eta_v}{V_g}$	in rpm	$\Delta p =$ pressure differential	in bar
			$n =$ speed	in rpm
Output torque	$T = \frac{V_g \cdot \Delta p \cdot \eta_{mh}}{20 \cdot \pi}$		$T_K =$ torque constants	in Nm/bar
	$= \frac{1,59 \cdot V_g \cdot \Delta p \cdot \eta_{mh}}{100}$	in Nm	$\eta_v =$ volumetric efficiency	
			$\eta_{mh} =$ mech.-hyd. efficiency	
			$\eta_t =$ overall efficiency	
	or $T = T_K \cdot \Delta p \cdot \eta_{mh}$	in Nm		
Output power	$P = \frac{2 \pi \cdot T \cdot n}{60 \cdot 1000} = \frac{T \cdot n}{9549}$			
	$= \frac{q_v \cdot \Delta p}{600} \cdot \eta_t$	in kW		

Preferred types, please state type and indent-no. when ordering

Type	Ident-No.	Type	Ident-No.
A2FE28/61W-NAL100	9419990	A2FE90/61W-NAL100	9416951
A2FE32/61W-NAL100	9418424	A2FE107/61W-NAL100	9419560
A2FE45/61W-NZL100	9437748	A2FE125/61W-NAL100	9418426
A2FE56/61W-NAL100	9437482	A2FE160/61W-NAL100	9421900
A2FE63/61W-NAL100	9437443	A2FE180/61W-NAL100	9421394
A2FE80/61W-NAL100	9419867		

sizes 28...180: production plant Elchingen; sizes 250...355: production plant Horb

Unit Dimension, Sizes 28...180

Before finalising your design, please request a certified drawing.

port plate 10

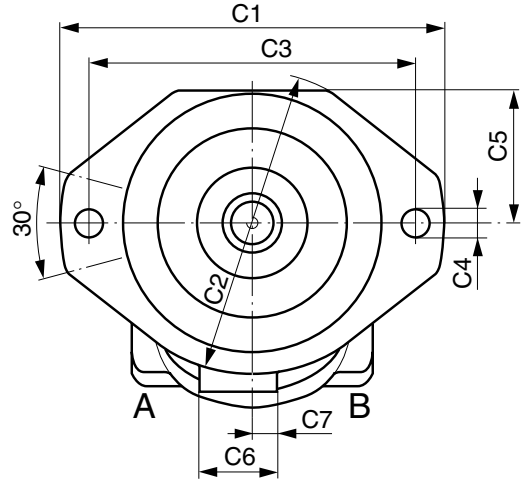
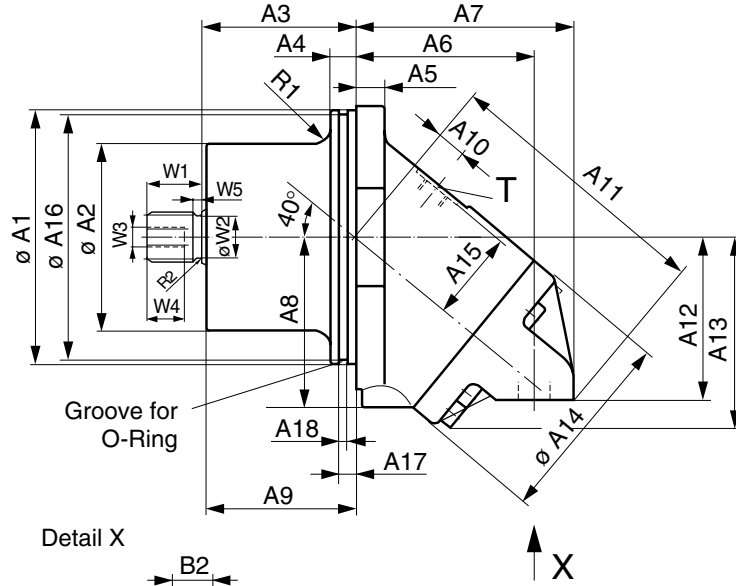

Detail X

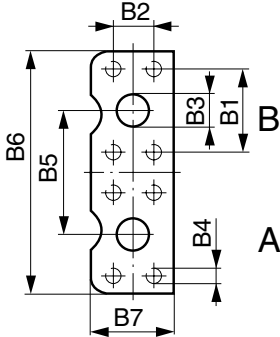

Connections
 A, B service line ports SAE
 420 bar (6000 psi)
 high pressure series
 T drain port

Size	C1	ØC2	C3	C4	C5	C6	C7
28, 32	188	154	160	14	71	42	12,5
45	235	190	200	18	82	47,5	15
56, 63	235	190	200	18	82	36	0
80, 90	260	220	224	22	98	40	0
107, 125	286	232	250	22	103	40	0
160, 180	286	232	250	22	104	42	0

Size	ØA1	ØA2	A3	A4	A5	A6	A7	A8	A9	A10	A11	A12	A13	ØA14	A15	A16	A17	A18
28, 32	135 _{h6}	94±1,5	88,8	15	16	94	114	95	87,1	19	149	91	106	106	51,5	128,7	10	5,2
45	160 _{h6}	117 ^{+1,5} ₋₂	92,3	15	18	109	133	106	90	18	167	102	119	118	56	153,7	10	5,2
56, 63	160 _{h6}	121 _{-0,5}	92,3	15	18	122	146	109	90	18	176	107	130	128	59	153,7	10	5,2
80, 90	190 _{h6}	139±1,3	110,8	15	20	127	157	123	106	15	198	121	145	138	66	183,7	10	5,2
107, 125	200 _{h6}	151±1,3	122,8	15	20	143	178	135	119	18	224	136	157	150	69	193,7	10	5,2
160, 180	200 _{h6}	170±1,6	122,8	15	20	169	211	134	119,3	19,5	244	149	188	180	78	193,7	10	5,2

Size	R1	O-Ring ¹⁾	B1	B2	ØB3	B4	Threads	B5	B6	B7	Port A, B	Drain ports T
28, 32	10	126x4	40,5	18,2	13	M8; 15 deep	59	115	40	SAE 1/2"	M16x1,5; 12 deep	
45	10	150x4	50,8	23,8	19	M10; 17 deep	75	147	49	SAE 3/4"	M18x1,5; 12 deep	
56, 63	10	150x4	50,8	23,8	19	M10; 17 deep	75	147	49	SAE 3/4"	M18x1,5; 12 deep	
80, 90	10	180x4	57,2	27,8	25	M12; 17 deep	84	166	60	SAE 1"	M18x1,5; 12 deep	
107, 125	16	192x4	66,7	31,8	32	M14; 19 deep	99	194	70	SAE 1 1/4"	M22x1,5; 12 deep	
160, 180	12	192x4	66,7	31,8	32	M14; 19 deep	99	194	70	SAE 1 1/4"	M22x1,5; 12deep	

¹⁾ The O-ring is not comprised in the delivery volume!

Size	Shaft end (DIN 5480)	W1	ØW2	W3	W4	W5	R2
28, 32	A W 30x2x30x14x9g	35,2	24,6	M10	22	8	1,6
28	Z W 25x1,25x30x18x9g	43,2	21,6	M8	19	15	1,6
45	A W 32x2x30x14x9g	35	26,6	M12	28	8	1,6
	Z W 30x2x30x14x9g	35	24,6	M12	28	8	1,6
56, 63	A W 35x2x30x16x9g	40	29,6	M12	28	8	1,6
	Z W 30x2x30x14x9g	35	24,6	M12	28	8	1,6

Size	Shaft end (DIN 5480)	W1	ØW2	W3	W4	W5	R2
80, 90	A W 40x2x30x18x9g	45	34,6	M16	36	8	2,5
	Z W 35x2x30x16x9g	40	29,6	M12	28	8	1,6
107, 125	A W 45x2x30x21x9g	50	39,6	M16	36	8	2,5
	Z W 40x2x30x18x9g	45	34,6	M12	28	8	2,5
160, 180	A W 50x2x30x24x9g	55	44,6	M16	36	11	4
	Z W 45x2x30x21x9g	50	39,6	M16	36	8	2,5

Unit Dimensions, Size 250

port plate 01

Before finalising your design, please request a certified drawing.

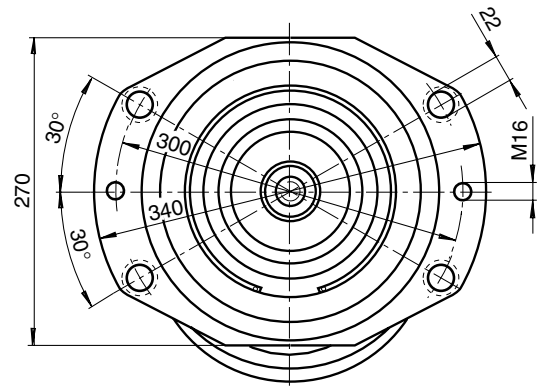
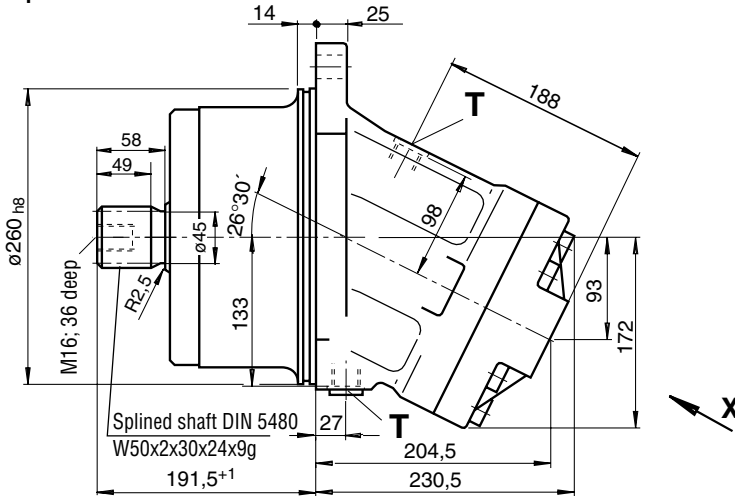

Teilansicht X

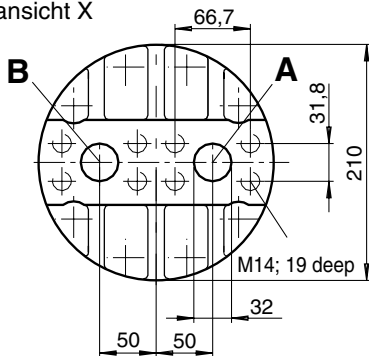

Connections

- A, B service line ports SAE 1 1/4"
- 420 bar (6000 psi) high pressure series
- T drain ports (1 port plugged) M22x1,5

Unit Dimensions, Size 355

port plate 10

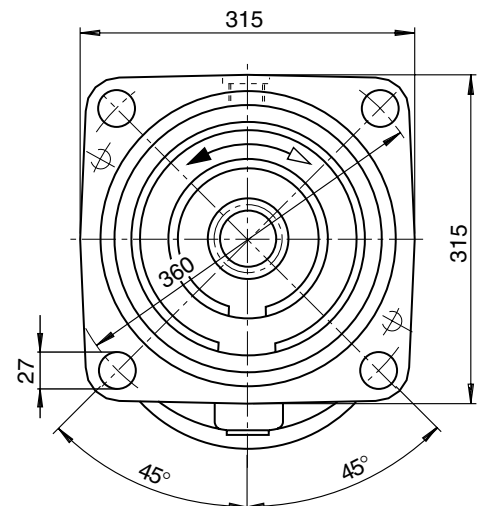
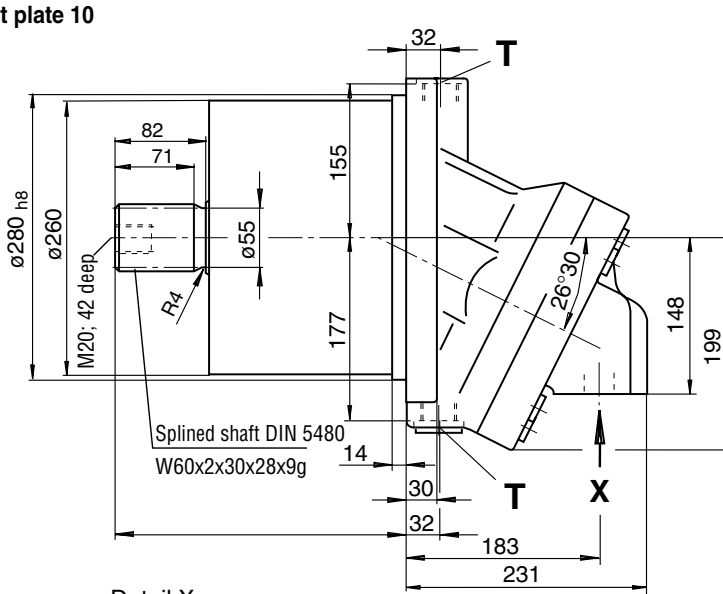

Detail X

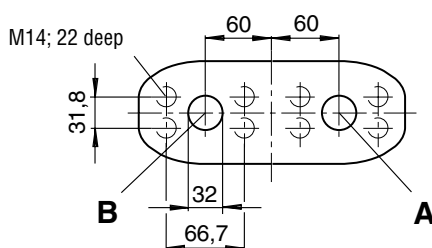

Connections

- A, B service line ports SAE 1 1/4"
- 420 bar (6000 psi) high pressure series
- T₁, T₂ drain ports (1 port plugged) M33x2

Before finalising your design, please request a certified drawing.
Subject to revision.

Port plate 17, 18 with integrated pressure relief valves, for mounting a motion control valve

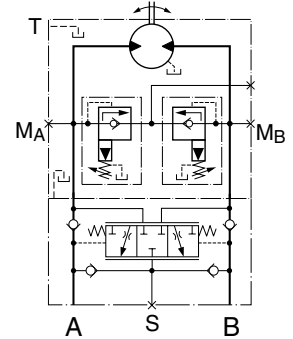
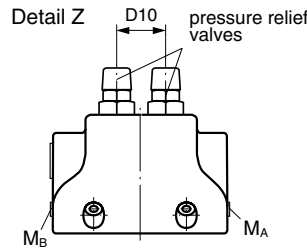
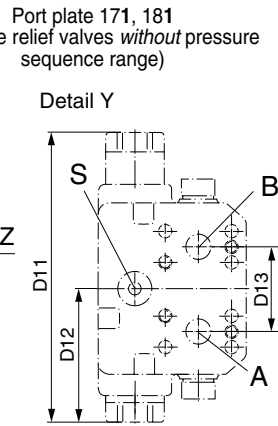
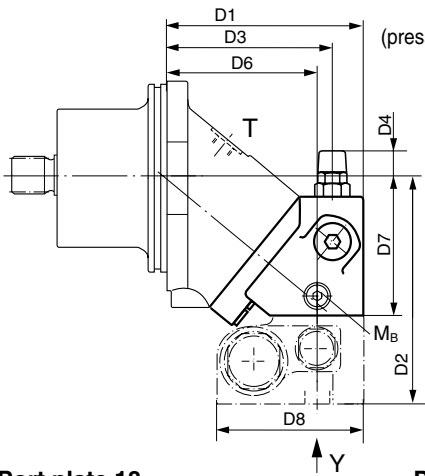

Port plate 18
suitable for mounting a Rexroth motion control valve (see RE 64317):
MHB16...18 (A2FM 28, 32, 45)
MHB16...18E (A2FM 56, 63)
MHB20...11 (A2FM 56, 63)
MHB20...18 (A2FM 80, 90)
MHB25...18 (A2FM 107, 125, 160, 180)

Port plate 17
suitable for mounting a Rexroth motion control valve (see RE 64317):
MHB20...18E (A2FM 107, 125)

Connections

- A, B service line ports SAE, 420 bar (see table below) (6000 psi high pressure series)
- S boosting (see table below)
- MA, MB test ports (plugged) M12x1,5

The motion control valve is not included in the ordering code and has to be indicated separately. We recommend total supply through Brueninghaus Hydromatik.

Port plate 19, with integrated pressure relief valves

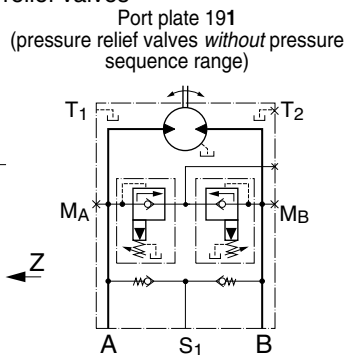
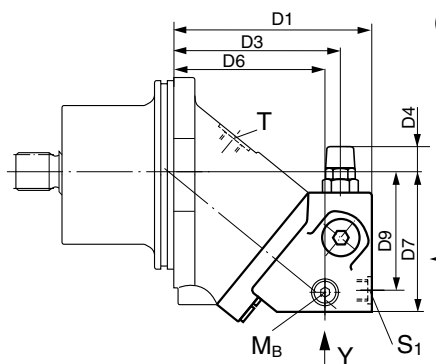

Port plate 192 (pressure relief valves *with* pressure sequence range)

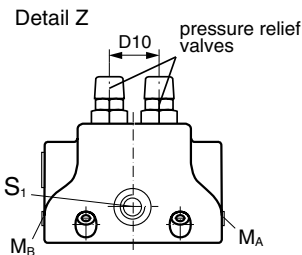
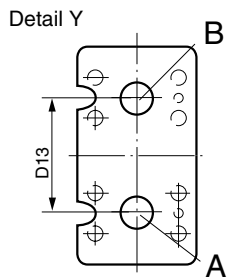
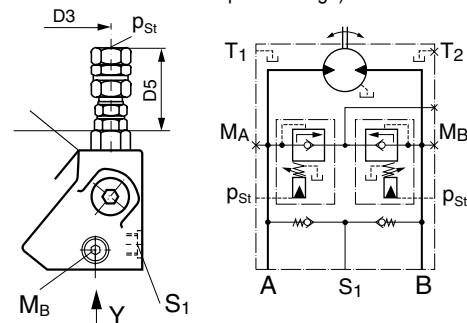

Connections

- A, B service line ports SAE, 420 bar (see table below) (6000 psi high pressure series)
- S1 boosting (see table below)
- pSt pilot pressure port G 1/4
- MA, MB test ports (plugged) M20x1,5 (Sizes 28...45)
M26x1,5 (Sizes 56...125)
M30x1,5 (Sizes 160...180)

Pressure relief valves

- without pressure sequence range (1) MHDBN16 (Sizes 28...45)
- without pressure sequence range (1) MHDBN22 (Sizes 56...90)
- without pressure sequence range (1) MHDBN32 (Sizes 107...180)
- with pressure sequence range (2) MHDBB16 (Sizes 28...45)
- with pressure sequence range (2) MHDBB22 (Sizes 56...90)
- with pressure sequence range (2) MHDBB32 (Sizes 107...180)

Size	D1	D2	D3	D4	D5	D6	D7	D8	D9	D10	D11	D12	D13	Ports A, B	Port S	Port S1
28, 32	145	170	127	25	63	110	102	115	87	36	215,5	93,5	66	SAE 3/4"	M 18x1,5	M 22x1,5
45	161	181	136	22	60	126	113	115	98	36	215,5	93,5	66	SAE 3/4"	M 18x1,5	M 22x1,5
56, 63 (+MHB16)	189	192	162	19	57	147	124	115	105	42	215,5	93,5	75	SAE 3/4"	M 18x1,5	M 26x1,5
(+MHB20)	189	192	162	29	57	147	124	137	105	42	235	96	75	SAE 3/4"	M 22x1,5	M 26x1,5
80, 90	193	202	165	17,5	55	151	134	137	114	42	235	96	75	SAE 1"	M 22x1,5	M 26x1,5
107, 125 (+MHB20)	216	217,5	184	10	48	168	149,5	137	130	53	286	120,5	84	SAE 1"	M 27x2	M 26x1,5
(+MHB25)	216	234,5	184	10	48	168	149,5	151,5	130	53	286	120,5	84	SAE 1 1/4"	M 27x2	M 26x1,5
160, 180	253	255	222	5	—	204	170	151,5	149	53	286	120,5	84	SAE 1 1/4"	M 27x2	M 26x1,5