

Axial Piston Variable Displacement Motor A6VM

RE 91 604/06.03
Replaces: 05.99

Open and closed circuits

Sizes 28 to 1000

Series 6

Sizes 28 to 200

Nominal pressure 400 bar

Maximum pressure 450 bar

Sizes 250 to 1000

Nominal pressure 350 bar

Maximum pressure 400 bar

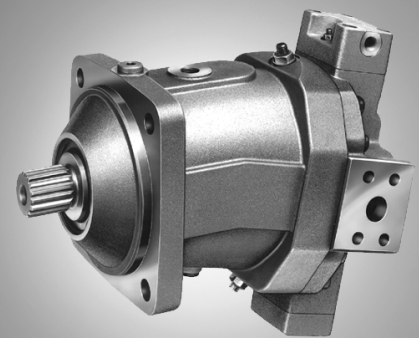

Contents

Ordering Code / Standard Program	2...3
Technical Data	4...7
HD - Hydraulic Control, Pilot Pressure Dependent	8...10
HZ - Hydraulic Two-Point Control	11
EP - Electrical Control With Proportional Solenoid	12...14
EZ - Electrical Two-Point Control, With Solenoid	15
HA - Automatic Control, High-Pressure Dependent	16...19
HD - Hydraulic Control, Speed Dependent	20...21
Unit Dimensions, Size 28	22...24
Unit Dimensions, Size 55	25...27
Unit Dimensions, Size 80	28...30
Unit Dimensions, Size 107	31...33
Unit Dimensions, Size 140	34...36
Unit Dimensions, Size 160	37...39
Unit Dimensions, Size 200	40...42
Unit Dimensions, Size 250	43...45
Unit Dimensions, Size 355	46...48
Unit Dimensions, Size 500	49...51
Unit Dimensions, Size 1000	52...54
Flushing and Boost Pressure Valve	55
Counterbalance Valve BVD	56...57
Speed Measurement	58
Swivel Angle Indicator	59
Connectors for Solenoids (for EP, EZ, HA.U, HA.R, DA only)	60
Installation and Startup Instructions	61
Safety Instructions	62

Features

- Variable displacement axial piston motor of bent axis design for hydrostatic transmissions in open and closed circuits
- For use in mobile and stationary applications
- The wide control range enables the variable displacement motor to satisfy the requirement for high rotational speed and high torque.
- The displacement is continuously variable from $V_{g \max}$ to $V_{g \min} = 0$.
- The output speed depends on the flow capacity of the pumps and the displacement of the motor.
- The torque increases with the pressure differential between the high and low pressure side and with increasing displacement.
- Wide control range with hydrostatic transmissions
- Wide selection of regulating and control devices
- Cost savings as no need for shiftable gearboxes and possibility to use smaller pumps
- Rugged, compact bearing system with long service life
- High power density
- Favorable start-up efficiency
- Low moment of inertia
- Large swivel range

Ordering Code / Standard Program

Pressure fluid

Mineral oil (no character), HFD for sizes 250-1000 only in combination with long-life bearing "L"	
HFB, HFC pressure fluid	Sizes 28 to 200 (no character)
	Sizes 250 to 1000 (only in combination with long-life bearing "L")
	E

Axial piston unit

bent-axis type, variable	A6V
--------------------------	------------

Drive shaft bearing

	28...200	250	355	500	1000
Standard bearing (no character)	●	●	●	●	-
Long-life bearing	-	●	●	●	●
					L

Operation mode

Motor (A6VE plug-in motor, see RE 91606)	M
--	----------

Size

± Displacement $V_{g \max}$ (cm ³)	28	55	80	107	140	160	200	250	355	500	1000
--	----	----	----	-----	-----	-----	-----	-----	-----	-----	------

Control device

		28	55	80	107	140	160	200	250	355	500	1000
Hydraulic control, Pilot pressure dependent	$\Delta p = 10$ bar HD1	●	●	●	●	●	●	●	●	●	●	●
	$\Delta p = 25$ bar HD2	●	●	●	●	●	●	●	●	●	●	●
	$\Delta p = 35$ bar HD3	-	-	-	-	-	-	-	●	●	●	●
Hydraulic two-point control	HZ	-	-	-	-	-	-	-	●	●	●	●
	HZ1	●	-	-	-	●	●	●	-	-	-	-
	HZ3	-	●	●	●	-	-	-	-	-	-	-
Electrical control, with proportional solenoid (sizes 28 to 200) ¹⁾	12 V EP1	●	●	●	●	●	●	●	●	●	●	●
	24 V EP2	●	●	●	●	●	●	●	●	●	●	●
Electrical two-point control, with solenoid	12 V EZ1	●	-	-	-	●	●	●	●	●	●	●
	24 V EZ2	●	-	-	-	●	●	●	●	●	●	●
	12 V EZ3	-	●	●	●	-	-	-	-	-	-	-
	24 V EZ4	-	●	●	●	-	-	-	-	-	-	-
Automatic control, without pressure rise	HA1	●	●	●	●	●	●	●	●	●	●	●
	High-pressure dependent with pressure rise $\Delta p = 100$ bar HA2	●	●	●	●	●	●	●	●	●	●	●
Hydraulic control, speed dependent	$p_{SI}/p_{HD} = 3/100$, hydraulic travel direction valve DA	-	-	-	-	-	-	-	●	●	●	○
	$p_{SI}/p_{HD} = 5/100$, hydraulic travel direction valve DA1	●	●	●	●	●	●	●	-	-	-	-
	electrical travel direction valve 12 V DA2	●	●	●	●	●	●	●	-	-	-	-
	+ electrical $V_{g \max}$ switch 24 V DA3	●	●	●	●	●	●	●	-	-	-	-
	$p_{SI}/p_{HD} = 8/100$, hydraulic travel direction valve DA4	●	●	●	●	●	●	●	-	-	-	-
	electrical travel direction valve 12 V DA5	●	●	●	●	●	●	●	-	-	-	-
+ electrical $V_{g \max}$ switch 24 V DA6	●	●	●	●	●	●	●	-	-	-	-	

Pressure control (for HD, EP only)

	28	55	80	107	140	160	200	250	355	500	1000
without pressure control (no character)	●	●	●	●	●	●	●	●	●	●	●
Pressure control direct		●	●	●	●	●	●	●	●	●	●
	direct, with 2nd pressure setting	●	●	●	●	●	●	2)	2)	2)	2)
	remotely controlled	-	-	-	-	-	-	●	●	●	●
											D
											E
											G

Overriding HA control (for HA1, HA2 only)

	28	55	80	107	140	160	200	250	355	500	1000
without override (no character)	●	●	●	●	●	●	●	●	●	●	●
Hydraulic override	●	●	●	●	●	●	●	●	●	●	●
Electrical override	12 V	●	●	●	●	●	●	-	-	-	-
	24 V	●	●	●	●	●	●	-	-	-	-
Electrical override + electrical travel direction valve	12 V	●	●	●	●	●	●	-	-	-	-
	24 V	●	●	●	●	●	●	-	-	-	-
											T
											U1
											U2
											R1
											R2

Series

Series 6, index 3	63
-------------------	-----------

Direction of rotation

when viewing shaft end, alternating	W
-------------------------------------	----------

Setting range for displacement ³⁾

	28	55	80	107	140	160	200	250	355	500	1000
$V_{g \min} = 0$ to $0.8 V_{g \max}$ (no character)	●	●	●	●	●	●	●	-	-	-	-
$V_{g \min} = 0$ to $0.4 V_{g \max}$ $V_{g \max} = V_{g \max}$ to $0.8 V_{g \max}$	-	-	-	-	-	-	-	●	●	●	●
$V_{g \min} > 0.4 V_{g \max}$ to $0.8 V_{g \max}$ $V_{g \max} = V_{g \max}$ to $0.8 V_{g \max}$	-	-	-	-	-	-	-	●	●	●	●
											1
											2

¹⁾ with proportioning valve (sizes 250 to 1000) ²⁾ supplied as standard with D version (sizes 250 to 1000)

³⁾ please specify precise values for $V_{g \min}$ and $V_{g \max}$ in plain text when placing your order: $V_{g \min} = \dots \text{ cm}^3$, $V_{g \max} = \dots \text{ cm}^3$

A6V	M			/	6	3	W	-	V											
-----	---	--	--	---	---	---	---	---	---	--	--	--	--	--	--	--	--	--	--	--

Pressure fluid

Axial piston unit

Transmission shaft bearing

Operation mode

Size

Control device

Series/Index

Direction of rotation

Setting range for displacement

Seals

FKM (fluor-caoutchouc)																					V
------------------------	--	--	--	--	--	--	--	--	--	--	--	--	--	--	--	--	--	--	--	--	---

Shaft end

	28	55	80	107	140	160	200	250	355	500	1000	
Splined shaft DIN 5480	●	●	●	●	-	●	●	-	-	-	-	A
	●	●	●	●	●	●	-	●	●	●	●	Z
Cylindrical shaft with key DIN 6885	-	-	-	-	-	-	-	●	●	●	●	P

Mounting flange to

	28	55	80	107	140	160	200	250	355	500	1000	
ISO 3019-2 – 4-hole	●	●	●	●	●	●	●	-	-	-	-	B
ISO 3019-2 – 8-hole	-	-	-	-	-	-	-	●	●	●	●	H

Service line connections

		28	55	80	107	140	160	200	250	355	500	1000	
Ports A, B: SAE rear	01	0	●	●	●	●	●	●	●	●	●	●	010
		7	●	●	●	●	●	●	●	●	●	●	017
Ports A, B: SAE side, opposite	02	0	●	●	●	●	●	●	●	●	●	●	020
		7	●	●	●	●	●	●	●	●	●	●	027
Port plate for fitting a counterbalance valve	08	0	-	-	-	-	-	-	○	-	-	-	080
Ports A, B: SAE side, opposite + rear	15	0	-	-	-	-	-	-	●	●	●	●	150
Port plate with pressure limiter, for fitting a counterbalance valve ^{1) 2)}	37	0	-	-	-	●	-	-	-	-	-	-	370
	38	0	-	●	●	●	●	-	-	-	-	-	380

Valves

no valves	0
with flushing and boost pressure valve	7

Speed measurement

	28	55	80	107	140	160	200	250	355	500	1000	
no speed measurement (no character)	●	●	●	●	●	●	●	●	●	●	●	
prepared for speed measurement (ID) ³⁾	●	●	●	●	●	●	●	-	-	-	-	D
prepared for speed measurement (HDD) ³⁾	-	●	●	●	○	●	●	○	○	○	○	F

Swivel angle indicator

	28	55	80	107	140	160	200	250	355	500	1000	
no swivel angle indicator (no character)	●	●	●	●	●	●	●	●	●	●	-	
with optical swivel angle indicator	-	-	-	-	-	-	-	-	●	●	●	V
with electrical swivel angle indicator	-	-	-	-	-	-	-	-	●	●	●	E

Connectors for solenoids (sizes 28 to 200 only) ⁴⁾

		EP1/2	EZ1/2	EZ3/4	HA.U.	HA.R.	DA.	
DEUTSCH DT04-2P-EP04	injection molded, without bidirectional quenching diode	●	●	-	-	-	●	P
2-pin	injection molded, with bidirectional quenching diode	-	○	-	-	-	○	Q
	with lead, without bidirectional quenching diode ^{5) 6)}	●	●	●	●	●	●	T
Hirschmann according to DIN EN 175 301-803-A, without bidirectional quenching diode ⁶⁾		●	●	●	●	●	●	H

Start of control

	28	55	80	107	140	160	200	250	355	500	1000	
at V _{g min} (standard for HA)	●	●	●	●	●	●	●	●	●	●	●	A
at V _{g max} (standard for HD, HZ, EP, EZ, DA)	●	●	●	●	●	●	●	●	●	●	●	B

¹⁾ only possible in combination with HD, EP, HA control

²⁾ complete order recommended, counterbalance valve, page 56 to 57

³⁾ complete order recommended, speed sensor, page 58

⁴⁾ for sizes 250 to 1000, the DIN connector is a Hirschmann one as standard (no character)

⁵⁾ under development for size 28

⁶⁾ not for new projects (sizes 28 to 200)

● = available ○ = under development - = not available

= preferred program

Technical Data

Pressure fluid

Before starting project planning, please refer to our data sheets RE 90220 (mineral oil), RE 90221 (environmentally-friendly pressure fluids) and RE 90223 (HF pressure fluids) for detailed information regarding the choice of pressure fluids and conditions of use.

The A6VM variable displacement motor is not suitable for use with HFA. If HFB, HFC and HFD or environmentally-friendly pressure fluids are being used, the constraints regarding technical data and seals mentioned in RE 90221 and RE 90223 must be observed.

If necessary, please contact us to discuss the type of pressure fluid you intend to use.

Viscosity range

We recommend that a viscosity (at operating temperature) for optimum efficiency and service life purposes of

$$v_{\text{opt}} = \text{optimum viscosity } 16 \text{ to } 36 \text{ mm}^2/\text{s}$$

be chosen, taken the circulation temperature (closed circuit) and reservoir temperature (open circuit) into account.

Limits of viscosity range

The following values apply in extreme cases:

Sizes 28 to 200:

$v_{\text{min}} = 5 \text{ mm}^2/\text{s}$
short-term ($t < 3 \text{ min}$) at max. permitted temperature of $t_{\text{max}} = +115^\circ\text{C}$.

$v_{\text{max}} = 1600 \text{ mm}^2/\text{s}$,
short-term ($t < 3 \text{ min}$) with cold start ($p < 30 \text{ bar}$, $n \leq 1000 \text{ rpm}$, $t_{\text{min}} = -40^\circ\text{C}$).

Sizes 250 to 1000:

$v_{\text{min}} = 10 \text{ mm}^2/\text{s}$
short-term ($t < 3 \text{ min}$) at max. permitted leakage-fuel temperature of $t_{\text{max}} = +90^\circ\text{C}$.

$v_{\text{max}} = 1600 \text{ mm}^2/\text{s}$,
short-term ($t < 3 \text{ min}$) with cold start ($p < 30 \text{ bar}$, $n \leq 1000 \text{ rpm}$, $t_{\text{min}} = -25^\circ\text{C}$).

Note that the maximum pressure fluid temperature must not be exceeded locally either (e.g. during storage).

Special measures are necessary at temperatures between -25°C and -40°C . Please contact us.

See RE 90300-03-B for detailed information about use at low temperatures.

Selection chart

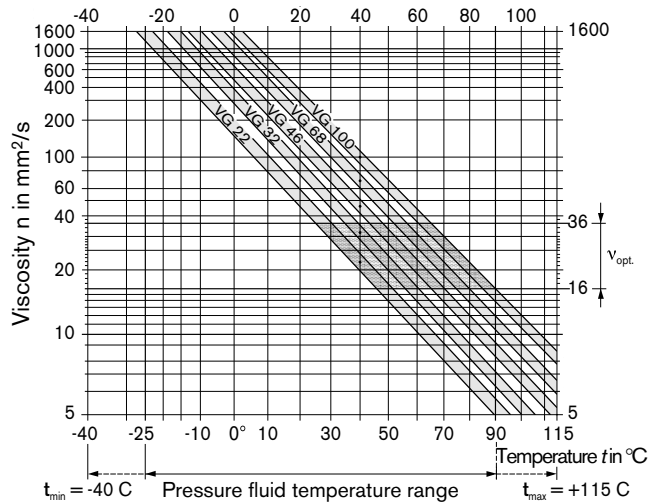

Details regarding the choice of pressure fluid

The correct choice of pressure fluid requires knowledge of the operating temperature in relation to the ambient temperature: in a closed circuit the circulation temperature, in an open circuit the reservoir temperature.

The pressure fluid should be chosen so that the viscosity in the operating temperature range is within the optimum area (v_{opt}) - the shaded area of the selection chart. We recommend that the higher viscosity class be selected in each case.

Example: At an operating temperature of 60°C , the viscosity classes VG 46 and VG 68 are within the optimum viscosity area (v_{opt} , shaded field). In this case we would recommend VG 68.

Please note: The leakage-fuel temperature, which is affected by pressure and rotational speed, is always higher than the circulation temperature or reservoir temperature. At no point in the system must the temperature be higher than 115°C (sizes 28 to 200) or 90°C (sizes 250 to 1000).

If this cannot be achieved due to unusual operating parameters or high ambient temperatures, we recommend flushing of the case via port U or the use of a flushing and boost pressure valve (see page 55).

Technical Data

Filtering

The finer the filtering, the cleaner the fluid and the greater the service life of the axial piston unit.

To ensure proper function of the axial piston unit, the pressure fluid must have a purity class of at least 20/18/15 according to ISO 4406.

At very high pressure fluid temperatures (90°C to max. 115°C, not permitted for sizes 250 to 1000), a purity class of at least 19/17/14 according to ISO 4406 is required.

Please contact us if these purity classes cannot be achieved.

Temperature range of shaft seal

The FKM shaft seal is suitable for case temperatures of -25°C to +115°C for sizes 28 to 200 and -25°C to +90°C for sizes 250 to 1000

Note:

A NBR shaft seal is necessary at temperatures below -25°C (permitted temperature range: -40°C to +90°C). Please contact us.

Operational pressure range

Maximum pressure on port A or B (pressure data according to DIN 24312)

for sizes 28 to 200

Nominal pressure p_N _____ 400 bar
 Maximum pressure p_{max} _____ 450 bar
 Total pressure (pressure A + pressure B) p_{max} _____ 700 bar

for sizes 250 to 1000

Nominal pressure p_N _____ 350 bar
 Maximum pressure p_{max} _____ 400 bar
 Total pressure (pressure A + pressure B) p_{max} _____ 700 bar

Please note:

Sizes 28 to 200: At the shaft end Z, a nominal pressure of $p_N = 315$ bar is permitted for the driven shaft end that is subjected to transverse bending (pinions, V-belts)!

Sizes 250 to 1000: Please contact us.

In cases of pulsating loading above 315 bar, we recommend the version with splined shaft A (sizes 28 to 200) or splined shaft Z (sizes 250 to 1000).

Direction of flow

Clockwise direction of rotation	Counterclockwise direction of rotation
A to B	B to A

Speed range

No limit to minimum speed n_{min} . If uniform motion is required, n_{min} must not be less than 50 rpm. See table on page 6 for maximum speed.

Long-Life bearing (sizes 250 to 1000)

For long service life and use with HF pressure fluids. Same external dimensions as motor with standard bearing. A long-life bearing can be retrofitted.

Flushing of bearing and case via port U recommended.

Flow (recommended)

Size	250	355	500	1000
$q_{v \text{ flow}}$ (L/min)	10	16	16	16

Case drain pressure

The service life of the sealing ring is affected by the speed of the motor and the case drain pressure. The permitted loading with intermittent case drain pressure depends on the rotational speed (see chart). Short-term ($t < 5$ s) pressure spikes of up to 6 bar absolute are permitted.

The average permanent case drain pressure must not exceed 3 bar absolute.

The pressure in the case must be equal to or greater than the external pressure on the shaft seal.

The pure mechanical resistance to case pressure is approximately 20 bar.

Sizes 28 to 200

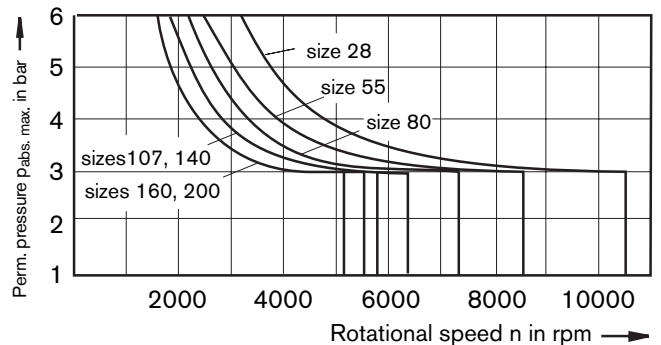

Sizes 250 to 1000

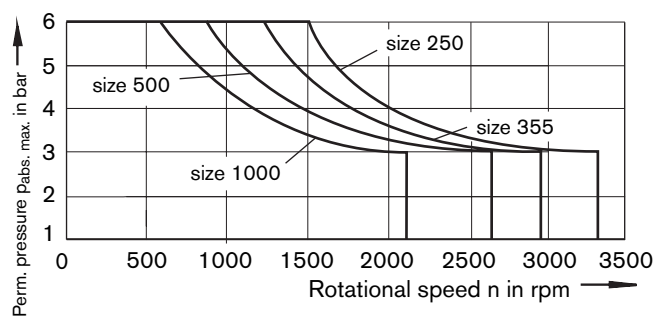

Effect of case pressure on start of control

An increase in the case pressure has an effect on the following settings when control of the variable displacement motor begins:
 HA1T (sizes 28 to 200) _____ increase
 HD, EP, HA, HA.T (sizes 250 to 1000): _____ increase
 DA : _____ reduction

The start of control is set in the factory at a case pressure of $p_{abs} = 2$ bar (sizes 28 to 200) and $p_{abs} = 1$ bar (sizes 250 to 1000).

Technical Data

Table of values (theoretical values, ignoring η_{mh} and η_v ; values rounded)

Size			28	55	80	107	140	160	200	250	355	500	1000
Displacement 1)	$V_{g\ max}$	cm ³	28.1	54.8	80	107	140	160	200	250	355	500	1000
	$V_{g\ 0}$	cm ³	0	0	0	0	0	0	0	0	0	0	0
Rotational speed max. (while adhering to max. permitted flow)	n_{max} at $V_{g\ max}$	rpm	5550	4450	3900	3550	3250	3100	2900	2700	2240	2000	1600
	n_{max1} at $V_g < V_{g,1}$	rpm	8750	7000	6150	5600	5150	4900	4600	3600	2950	2650	2100
		$V_{g,1}$ cm ³	18	35	51	68	88	101	126	188	270	377	762
	$n_{max\ 0}$ at $V_{g\ 0}$	rpm	10450	8350	7350	6300	5750	5500	5100	3600	2950	2650	2100
Flow max.	qV_{max}	L/min	156	244	312	380	455	496	580	675	795	1000	1600
Torque max.	T_{max} at $V_{g\ max}$ 2)	Nm	179	349	509	681	891	1019	1273	1391	1978	2785	5571
Torsional rigidity		Nm/rad	360	700	1150	1560	2095	2320	2910	3733	5092	8228	18753
Mass moment of inertia J around output shaft		kgm ²	0.0014	0.0042	0.0080	0.0127	0.0207	0.0253	0.0353	0.061	0.102	0.178	0.550
Filling capacity		L	0.5	0.75	1.2	1.5	1.8	2.4	2.7	3.0	5.0	7.0	16.0
Mass (approx.)	m	kg	16	26	34	47	60	64	80	90	170	210	430

1) The minimum and maximum displacement are continuously variable, see model codes on page 2.
 (default setting sizes 250 to 1000 unless specified in order: $V_{g\ min} = 0.2 \cdot V_{g\ max}$, $V_{g\ max} = V_{g\ max}$).

2) sizes 28 to 200: $\Delta p = 400$ bar; sizes 250 to 1000: $\Delta p = 350$ bar

Minimum inlet pressure on service line port A(B)

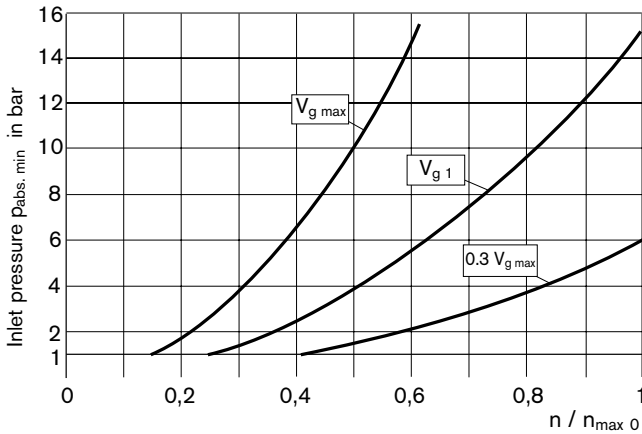

Permitted displacement in relation to rotational speed

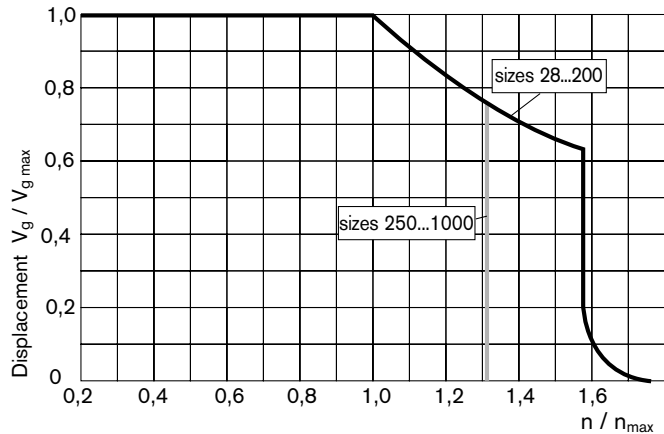



To prevent damage to the variable displacement motor, there has to be a minimum inlet pressure in the inlet area. The minimum inlet pressure depends on the speed and swivel angle (displacement) of the variable displacement motor.

Please contact us if these conditions cannot be satisfied.

Technical Data

Permissible transverse and axial forces on drive shaft

Size			28	55	80	107	140	160	200	250	355	500	1000	
Transverse force, max. ¹⁾ F_q at distance of (from shaft collar)		$F_{q \max}$	N	5696	10440	13114	15278	17808	20320	22896	1200 ²⁾	1500 ²⁾	1900 ²⁾	2600 ²⁾
	a	mm	12.5	15	17.5	20	22.5	22.5	25	41	52.5	52.5	67.5	
Axial force, max. ³⁾ F_{ax}		$-F_{ax \max}$	N	315	500	710	900	1030	1120	1250	1200	1500	1900	2600
		$+F_{ax \max}$	N	315	500	710	900	1030	1120	1250	4000	5000	6250	10000
Permissible axial force/bar operating pressure		$\pm F_{ax \text{ zul}} / \text{bar}$	N/bar	4.6	7.5	9.6	11.3	13.3	15.1	17.0	4)	4)	4)	4)

1) During intermittent operation (sizes 28 to 200).

2) When stopped or when axial piston unit working in pressureless conditions. Higher forces are permitted when under pressure. Please contact us.

3) Max. permissible axial force when stopped or when axial piston unit working in pressureless conditions.

4) Please contact us.

When considering the permissible axial force, the force-transfer direction must be taken into account.

$-F_{ax \max}$ = increase in service life of bearings

$+F_{ax \max}$ = reduction in service life of bearings
(avoid if at all possible)

Effect of transverse force F_q on the service life of the bearings

By selecting a suitable force-transfer direction of F_q , the stress on the bearing caused by the internal transmission forces can be reduced, thus achieving the optimum service life for the bearing.

Recommended position of mating gear depending on direction of rotation. Examples:

Toothed gear output

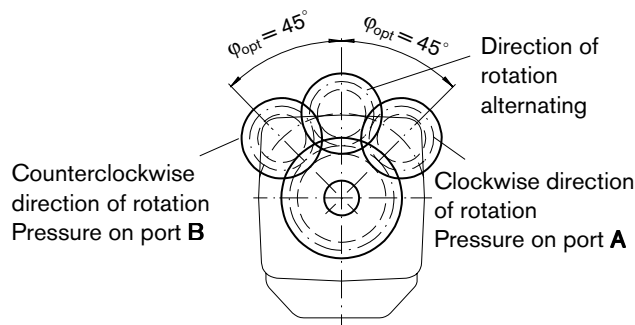

V-belt output

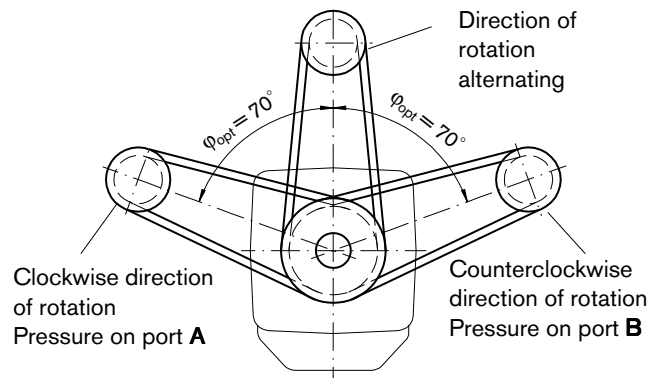

Determining the size

Flow $q_v = \frac{V_g \cdot n}{1000 \cdot \eta_v}$ in l/min

Output speed $n = \frac{q_v \cdot 1000 \cdot \eta_v}{V_g}$ in rpm

Output torque $T = \frac{V_g \cdot \Delta p \cdot \eta_{mh}}{20 \cdot \pi}$ in Nm

Output power $P = \frac{2 \pi \cdot T \cdot n}{60000} = \frac{q_v \cdot \Delta p}{600} \cdot \eta_t$ in kW

V_g = Displacement per revolution in cm^3

Δp = Differential pressure in bar

η_v = Volumetric efficiency

η_{mh} = Mechanical-hydraulic efficiency

η_t = Overall efficiency

HD - Hydraulic Control, Pilot Pressure Dependent

The pilot pressure dependent hydraulic system permits continuous control of the displacement according to the pilot pressure signal. The control is proportional to the pilot pressure present on port X.

Normal version:

- start of control at $V_{g \max}$ (max. torque, min. speed)
- end of control at $V_{g \min}$ (min. torque, max. permitted speed)

Please note:

- Maximum permitted pilot pressure: 100 bar
- The required charge oil is taken from the high pressure. Therefore, a Δp of at least 15 bar on the supply pressure is needed. If the Δp on the supply pressure is < 15 bar (e.g. when idle), an auxiliary pressure of at least 15 bar above the supply pressure must be applied on port G via an external non-return valve.
- Please state the required start of control in plain text when placing your order, e.g.: start of control at 10 bar

The following only applies to sizes 250 to 1000:

- The start of control and the HD characteristic are influenced by the pressure in the case. A rise in pressure in the case causes an increase in the start of control and a corresponding parallel movement of the performance curve (see page 5).
- Fluid will escape from port X at the rate of 0.3 l/min due to internal leakage (operating pressure > pilot pressure). The actuation must be designed appropriately to ensure correct control pressure.

HD1: pilot pressure rise $\Delta p_s = 10$ bar

A rise in pilot pressure of 10 bar on port X causes a reduction in the displacement from $V_{g \max}$ to 0 cm³ (sizes 28 to 200) or from $V_{g \max}$ to 0.2 $V_{g \max}$ (sizes 250 to 1000).

Start of control (setting range) _____ 2 – 20 bar

Default setting: Start of control at 3 bar (end at 13 bar)

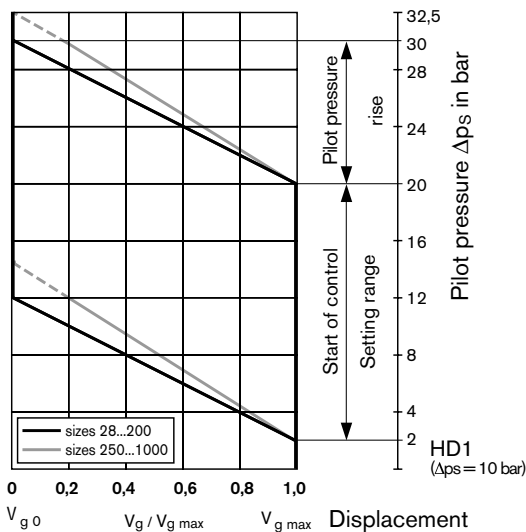

HD2: pilot pressure rise $\Delta p_s = 25$ bar

A rise in pilot pressure of 25 bar on port X causes a reduction in the displacement from $V_{g \max}$ to 0 cm³ (sizes 28 to 200) or from $V_{g \max}$ to 0.2 $V_{g \max}$ (sizes 250 to 1000).

Start of control, setting range _____ 5 – 50 bar

Default setting: Start of control at 10 bar (end at 35 bar)

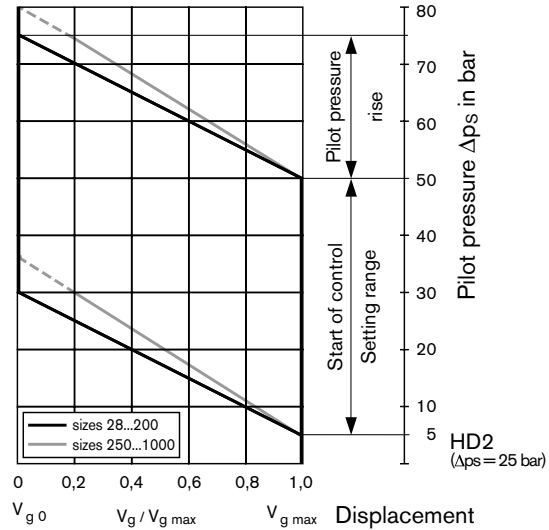

HD3: pilot pressure rise $\Delta p_s = 35$ bar

A rise in pilot pressure of 35 bar on port X causes a reduction in the displacement from $V_{g \max}$ to 0.2 $V_{g \max}$ (sizes 250 to 1000).

Start of control, setting range _____ 7 – 50 bar

Default setting: Start of control at 10 bar (end at 45 bar)

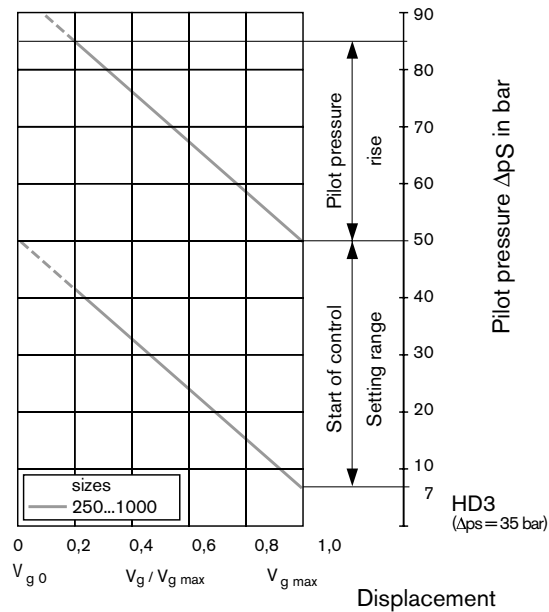

HD - Hydraulic Control, Pilot Pressure Dependent

HD1, HD2, HD3: Hydraulic control, pilot pressure dependent

Sizes 28 to 200

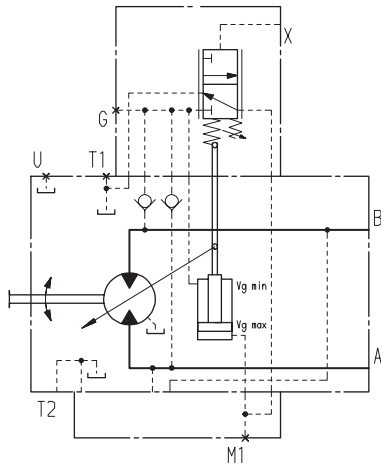

Sizes 250 to 1000

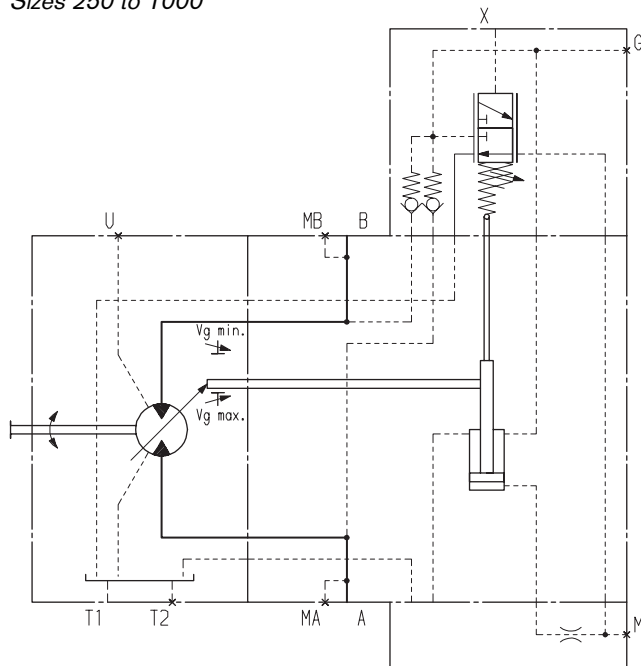

HD.D: pressure control, direct

The pressure control overlays the HD function. If the load moment or a reduction in the swivel angle of the motor causes the system pressure to rise, the motor will start to swivel to a greater angle when the pressure reaches the value set on the pressure control.

The increase in the displacement and the resulting reduction in pressure cause the controller deviation to decrease. With the increase in displacement the motor develops more torque, while the pressure remains constant.

Setting range on pressure control valve:

Sizes 28 to 200 _____ 80 – 400 bar

Sizes 250 to 1000 _____ 80 – 350 bar

Sizes 28 to 200

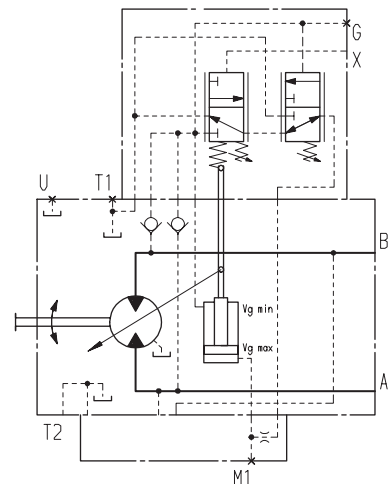

Sizes 250 to 1000

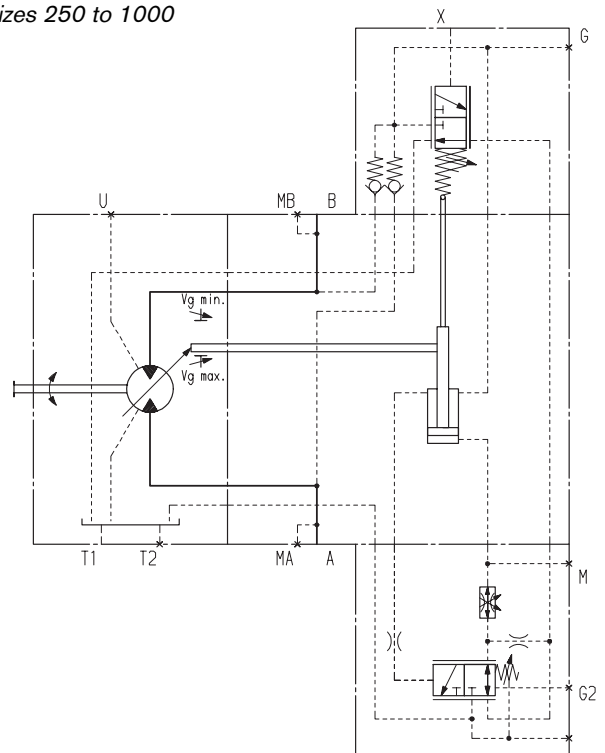

HD - Hydraulic Control, Pilot Pressure Dependent

HD.E: pressure control, direct with 2nd pressure setting

Sizes 28 to 200

Connecting an external pilot pressure to port G2 allows the pressure regulator setting to be overridden and a second pressure setting to be used.

Required pilot pressure on port G2:

Sizes 28 to 200 _____ $p_{St} = 20 - 50 \text{ bar}$

Please specify the 2nd pressure setting in plain text when placing your order.

Sizes 28 to 200

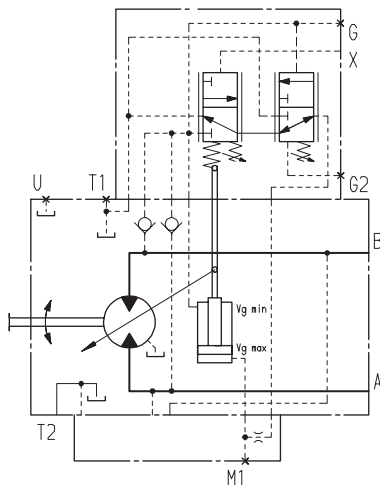

Sizes 250 to 1000 (HD.D)

Pressure control with 2nd pressure setting provided as standard with HD.D (see page 9).

Connecting an external pilot pressure to port G2 allows the pressure regulator setting to be overridden and a second pressure setting to be used.

Required pilot pressure on port G2:

Sizes 250 to 1000 _____ $p_{St} \geq 100 \text{ bar}$

Please specify the 2nd pressure setting in plain text when placing your order.

HD.G: pressure control, remote

Sizes 250 to 1000

When the specified pressure is reached, the remote pressure control regulates the motor continuously up to the maximum displacement $V_{g \max}$. A pressure limiter (not in the scope of supply) controls the internal discharge stop valve. The pressure limiter is separate from the motor and is connected to X3. If the pressure setpoint value is not reached, the valve is subjected to even pressure from both sides, in addition to the spring force, and remains closed. The pressure setpoint lies between 80 bar and 350 bar. When this pressure is obtained on the separate pressure limiter, the pressure limiter opens and the pressure on the reservoir side of the spring reduces. The internal control valve switches and the motor swivels to maximum displacement $V_{g \max}$.

The default value for the differential pressure on the control valve is 25 bar. We recommend the following external pressure limiter:

DBD 6 (hydraulic) to RE 25402

The max. line length must not exceed 2 m.

Sizes 250 to 1000

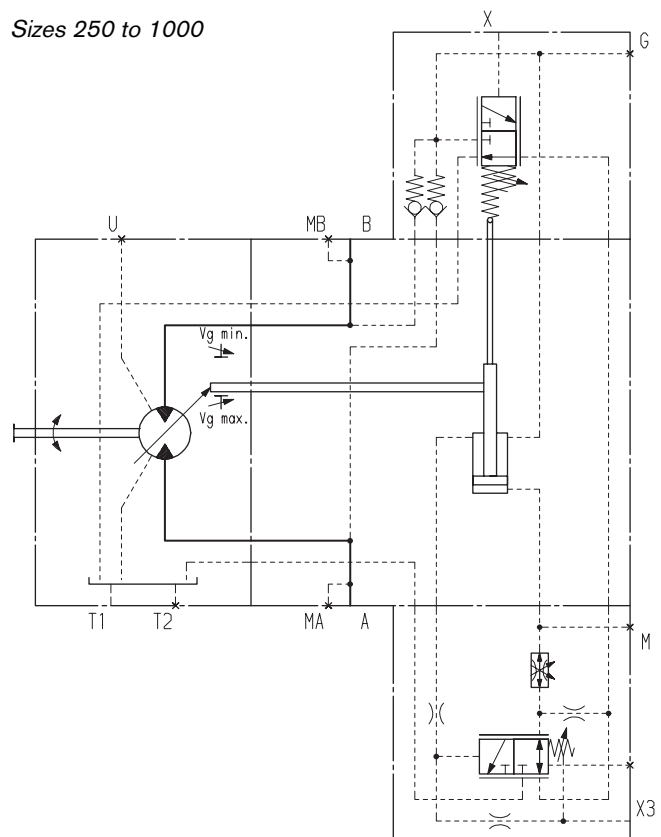

HZ - Hydraulic Two-Point Control

Hydraulic two-point control allows the displacement to be set to $V_{g \min}$ or $V_{g \max}$ by switching the pilot pressure on port X on or off.

- no pilot pressure $\hat{=}$ position at $V_{g \max}$
- pilot pressure switched on (> 10 bar) $\hat{=}$ position at $V_{g \min}$

Normal version:

- start of control at $V_{g \max}$ (max. torque, min. speed)
- end of control at $V_{g \min}$ (min. torque, max. permitted speed)

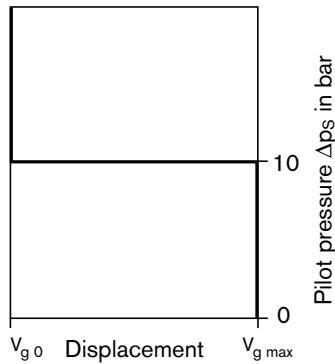

Please note:

- Maximum permitted pilot pressure: 100 bar
- The required charge oil is taken from the high pressure. Therefore, a Δp of at least 15 bar on the supply pressure is needed. If the Δp on the supply pressure is < 15 bar (when idle), an auxiliary pressure of at least 15 bar above the supply pressure must be applied on port G via an external non-return valve.

The following only applies to sizes 250 to 1000:

- Fluid will escape from port X at the rate of 0.3 l/min due to internal leakage (operating pressure $>$ pilot pressure). The actuation must be designed appropriately to ensure correct control pressure.

HZ: Hydraulic two-point control

Sizes 250 to 1000

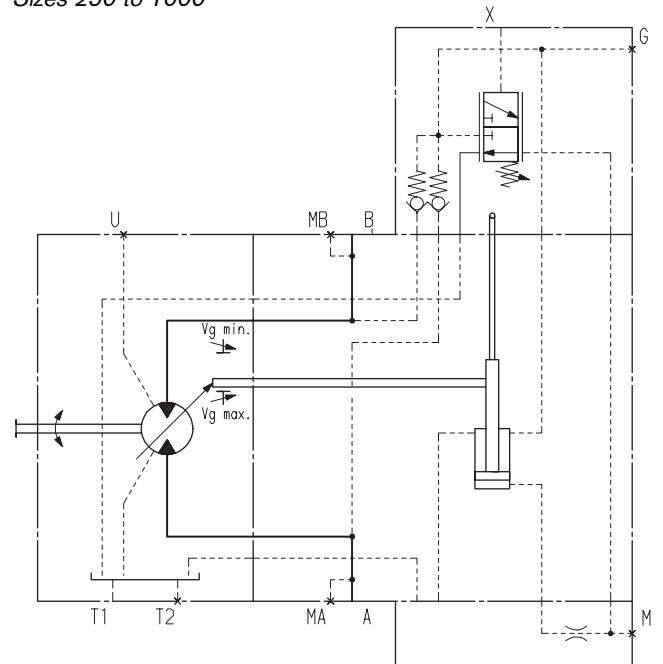

HZ1: Hydraulic two-point control

Sizes 28, 140, 160, 200

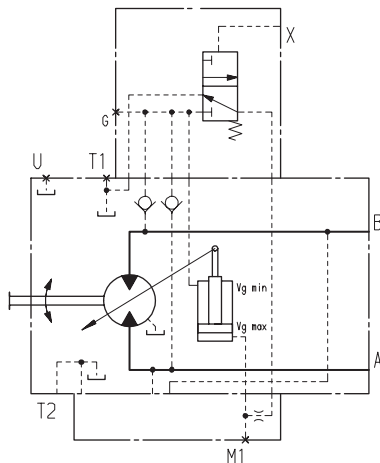

HZ3: Hydraulic two-point control

Sizes 55, 80, 107

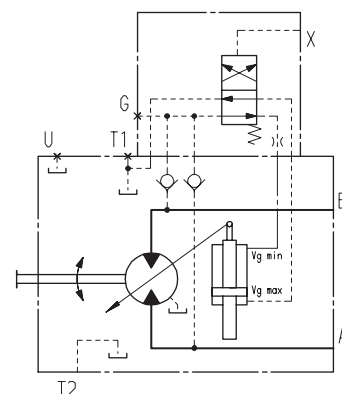

EP - Electrical Control With Proportional Solenoid

Electrical control using a proportional solenoid (sizes 28 to 200) or proportioning valve (sizes 250 to 1000) permits continuous control of the displacement according to an electrical signal. The control is proportional to the applied electrical control current.

In the case of sizes 250 to 1000, an external pressure of $p_{min} = 30$ bar is necessary for the charge oil supply to port P ($p_{max} = 100$ bar).

Normal version:

- start of control at $V_{g\ max}$ (max. torque, min. speed)
- end of control at $V_{g\ min}$ (min. torque, max. permitted speed)

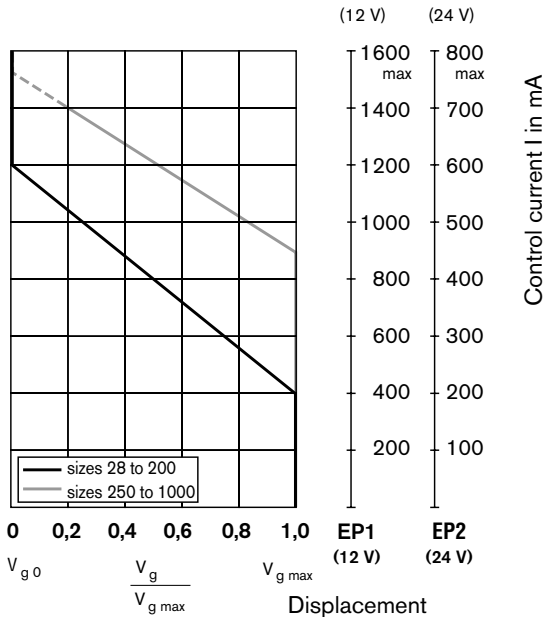

The rate of control or limiting of the displacement (limiting the swiveling range) can be achieved electrically using the following control units:

- **MC** control unit (see RE 95050)
- **RC** control unit (see RE 95200)
- **PV** proportional amplifier (see RE 95023)
- **VT 2000** electrical amplifier, series 5X (see RE 29904) (for stationary application)

EP1, EP2: Electrical control with proportional solenoid

Sizes 28 to 200

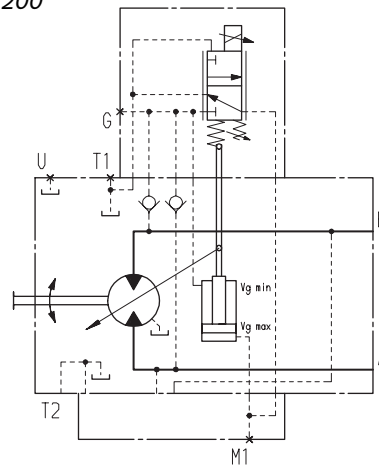

EP1, EP2: Electrical control with proportioning valve

Sizes 250 to 1000

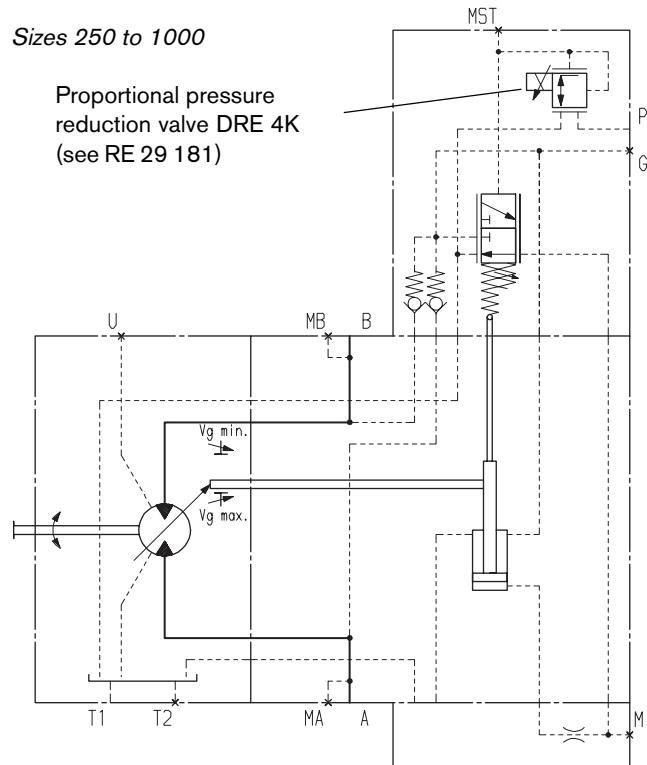

Please note:

- The required charge oil is taken from the high pressure, so a Δp of at least 15 bar on the supply pressure is needed. If the Δp on the supply pressure is < 15 bar (when idle), an auxiliary pressure of at least 15 bar above the supply pressure must be applied on port G via an external non-return valve.
- The start of control and the EP characteristic are influenced by the pressure in the case. A rise in pressure in the case causes an increase in the start of control and a corresponding parallel movement of the performance curve (sizes 250 to 1000, see page 5).

Technical data, solenoid in EP1, EP2	EP1	EP2
Voltage	12 V ($\pm 20\%$)	24 V ($\pm 20\%$)
Control current sizes 28 to 200		
Control starts at $V_{g\ max}$	400 mA	200 mA
Control ends at $V_{g\ min}$	1200 mA	600 mA
Control current sizes 250 to 1000		
Control starts at $V_{g\ max}$	900 mA	450 mA
Control ends at $V_{g\ min}$	1400 mA	700 mA
Maximum current	1,54 A	0,77 A
Nominal resistance (at 20°C)	5,5 Ω	22,7 Ω
Dither frequency	100 Hz	100 Hz
Operating time	100 %	100 %
Degree of protection	see connector design, page 60	

EP - Electrical Control With Proportional Solenoid

EP.D: Electrical control with pressure control, direct

The pressure control overlays the EP function. If the load moment or a reduction in the swivel angle of the motor causes the system pressure to rise, the motor will start to swivel to a greater angle when the pressure reaches the value set on the pressure control.

The increase in the displacement and the resulting reduction in pressure cause the controller deviation to decrease. With the increase in displacement the motor develops more torque, while the pressure remains constant.

Setting range on pressure-control valve:

Sizes 28 to 200 _____ 80 – 400 bar

Sizes 250 to 1000 _____ 80 – 350 bar

Sizes 28 to 200

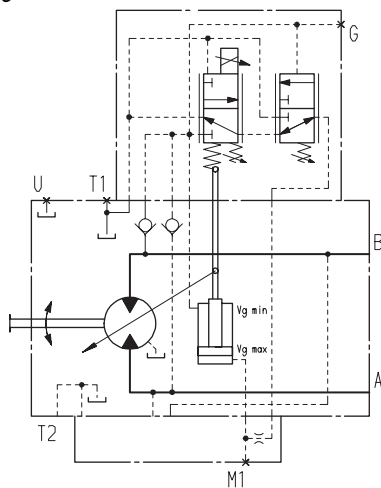

Sizes 250 to 1000

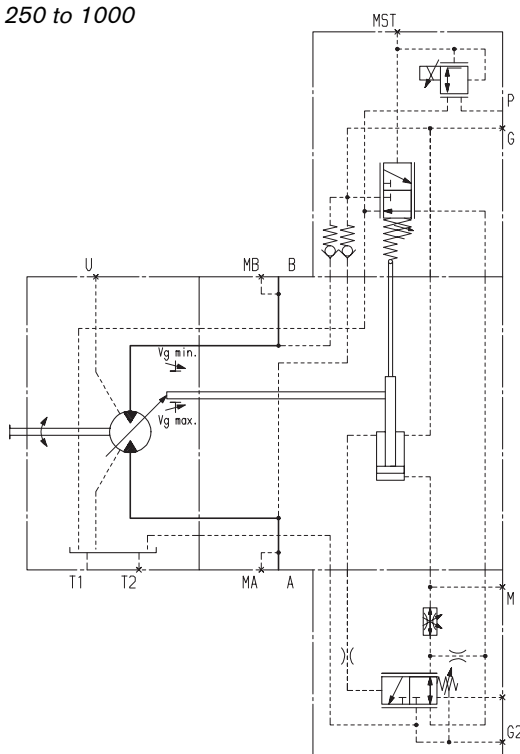

EP.E: pressure control, direct with 2nd pressure setting

Sizes 28 to 200

Connecting an external pilot pressure to port G2 allows the pressure regulator setting to be overridden and a second pressure setting to be used.

Required pilot pressure on port G2:

Sizes 28 to 200 _____ $p_{st} = 20 - 50$ bar

Please specify the 2nd pressure setting in plain text when placing your order.

Sizes 28 to 200

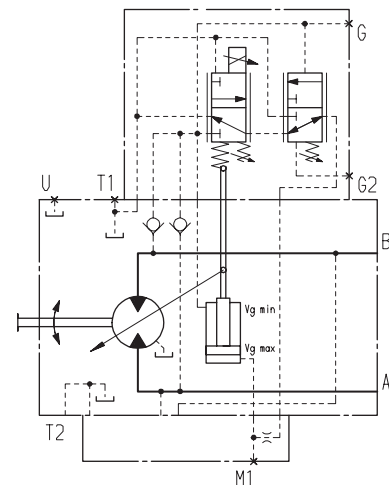

Sizes 250 to 1000 (EP.D)

Pressure control with 2nd pressure setting provided as standard with EP.D (see circuit diagram).

Connecting an external pilot pressure to port G2 allows the pressure regulator setting to be overridden and a second pressure setting to be used.

Required pilot pressure on port G2:

Sizes 250 to 1000 _____ $p_{st} \geq 100$ bar

Please specify the 2nd pressure setting in plain text when placing your order.

EP - Electrical Control With Proportional Solenoid

EP.G: Electrical control with pressure control, remote

Sizes 250 to 1000

When the specified pressure is reached, the remote pressure control regulates the motor continuously up to the maximum displacement $V_{g \max}$. A pressure limiter (not in the scope of supply) controls the internal discharge stop valve. The pressure limiter is separate from the motor and is connected to X3.

If the specified pressure value is not reached, the valve is subjected to even pressure from both sides, in addition to the spring force, and remains closed. The pressure setpoint lies between 80 bar and 350 bar. When this pressure is reached on the separate pressure limiter, the limiter opens and the pressure on the reservoir side of the spring reduces. The internal control valve switches and the motor swivels to maximum

displacement $V_{g \max}$. The default value for the differential pressure on the control valve is 25 bar. We recommend the following external pressure limiter:

DBD 6 (hydraulic) to RE 25402

The max. line length must not exceed 2 m.

Sizes 250 to 1000

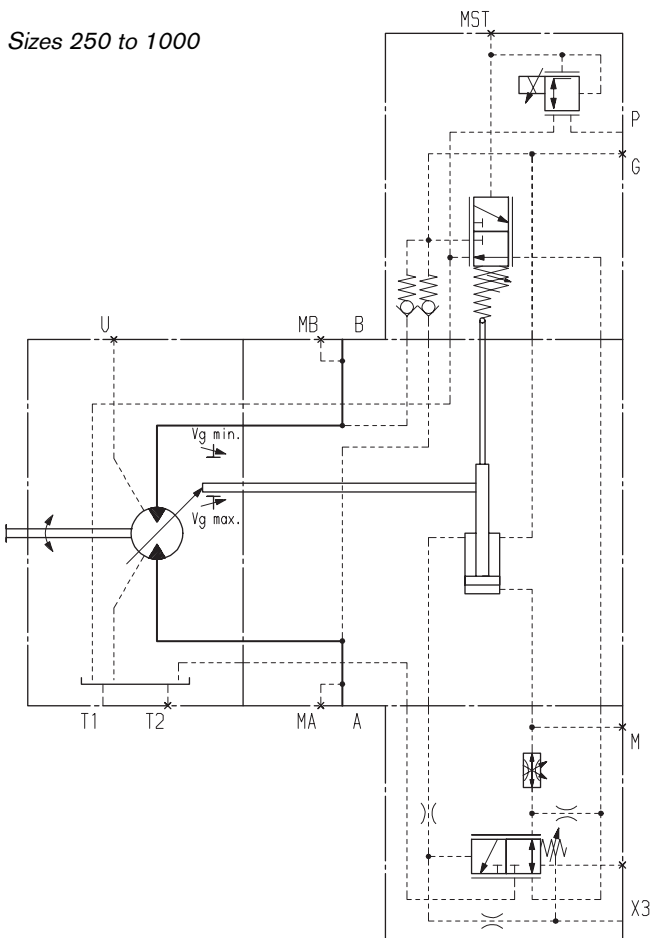

EZ - Electrical Two-Point Control, With Solenoid

Electrical two-point control with a solenoid allows the displacement to be set to $V_{g \min}$ or $V_{g \max}$ by switching the electrical current to the solenoids on or off.

Please note:

- The required charge oil is taken from the high pressure, so a Δp of at least 15 bar on the supply pressure is needed. If the Δp on the supply pressure is < 15 bar (when idle), an auxiliary pressure of at least 15 bar above the supply pressure must be applied on port G via an external non-return valve.

Technical data, solenoid in EZ1, EZ2	EZ1	EZ2
Voltage	12 V (± 20 %)	24 V (± 20 %)
Neutral position $V_{g \max}$	de-energized	de-energized
$V_{g \min}$ position	Current on	Current on
Nominal resistance (at 20°C)	5.5 Ω	21.7 Ω
Nominal output	26.2 W	26.5 W
Active current, minimum required	1.32 A	0.67 A
Operating time	100 %	100 %
Degree of protection	see connector design, page 60	

Technical data, solenoid in EZ3, EZ4	EZ3	EZ4
Voltage	12 V (± 20 %)	24 V (± 20 %)
Neutral position $V_{g \max}$	de-energized	de-energized
$V_{g \min}$ position	Current on	Current on
Nominal resistance (at 20°C)	4.8 Ω	19.2 Ω
Nominal output	30 W	30 W
Active current, minimum required	1.5 A	0.75 A
Operating time	100 %	100 %
Degree of protection	see connector design, page 60	

EZ1, EZ2: Electrical two-point control

Sizes 28, 140, 160, 200

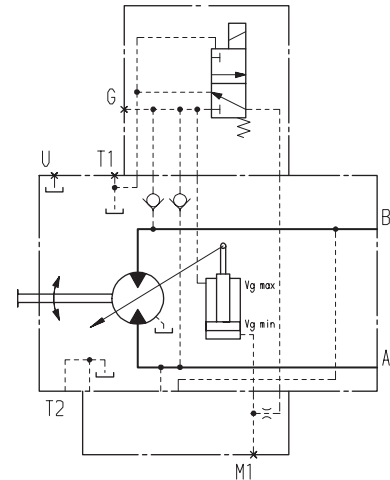

EZ3, EZ4: Electrical two-point control

Sizes 55, 80, 107

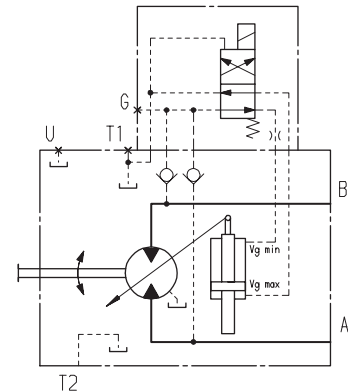

EZ1, EZ2: Electrical two-point control

Sizes 250 to 1000

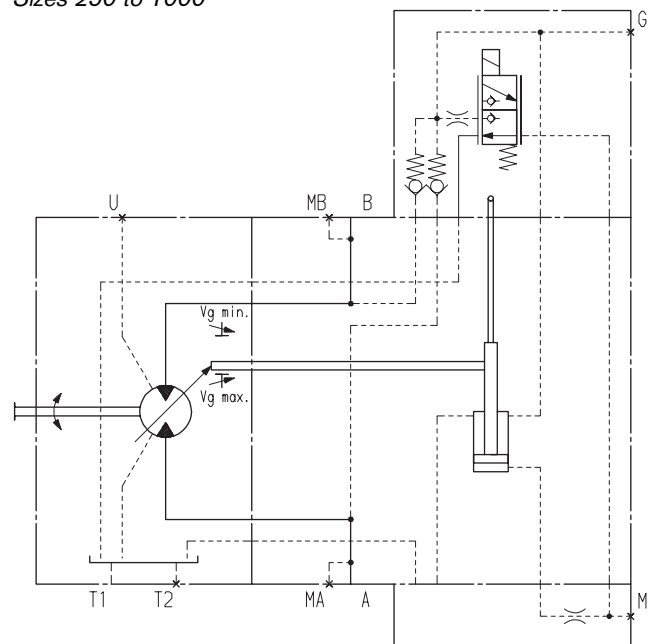

HA - Automatic Control, High-Pressure Dependent

In the case of automatic high-pressure dependent control, the displacement is set automatically according to the operating pressure.

The control unit measures the internal operating pressure at A or B (no control line required) and, when the pressure reaches the setpoint value of $V_{g \min}$ set on the controller, swivels with increasing operating pressure to $V_{g \max}$.

Normal version HA1, HA2:

Start of control at $V_{g \min}$ (min. torque, max. speed)

End of control at $V_{g \max}$ (max. torque, min. speed)

Please note:

- For safety reasons, winch drives are not permitted with start of control at $V_{g \min}$ (default with HA).

- The required charge oil is taken from the high pressure, so a Δp of at least 15 bar on the supply pressure is needed. If the Δp on the supply pressure is < 15 bar (when idle), an auxiliary pressure of at least 15 bar above the supply pressure must be applied on port G via an external non-return valve.

- The start of control and the HA characteristic are influenced by the pressure in the case. A rise in pressure in the case causes an increase in the start of control and a corresponding parallel movement of the performance curve. Only with HA1, HA2, HA.T (sizes 250 to 1000) and HA1T (sizes 28 to 200), see page 5.

- Fluid will escape from port X at the rate of 0.3 l/min due to internal leakage (operating pressure $>$ pilot pressure). The actuation must be designed appropriately to ensure correct control pressure.

Only with HA.T control.

HA1: approximate with no pressure rise

A rise in operating pressure of $\Delta p \leq 10$ bar causes an increase in the displacement from 0 cm^3 to $V_{g \max}$ (sizes 28 to 200) or from 0,2 $V_{g \max}$ to $V_{g \max}$ (sizes 250 to 1000).

Start of control, setting range

Sizes 28 to 200 _____ 80 – 350 bar

Sizes 250 to 1000 _____ 80 – 340 bar

Please state the required start of control in plain text when placing your order, e.g.: start of control at 300 bar

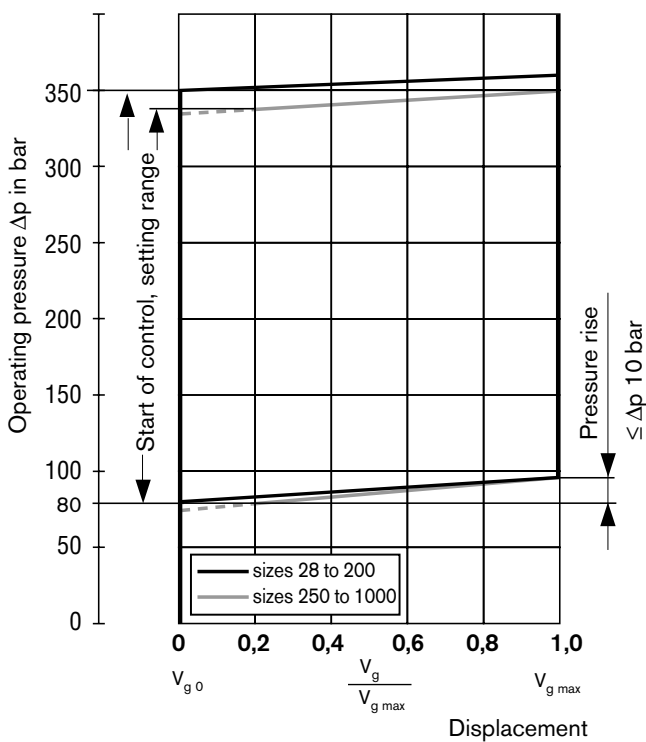

Sizes 28 to 200

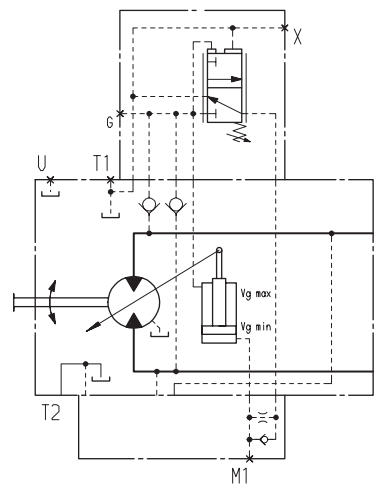

Sizes 250 to 1000

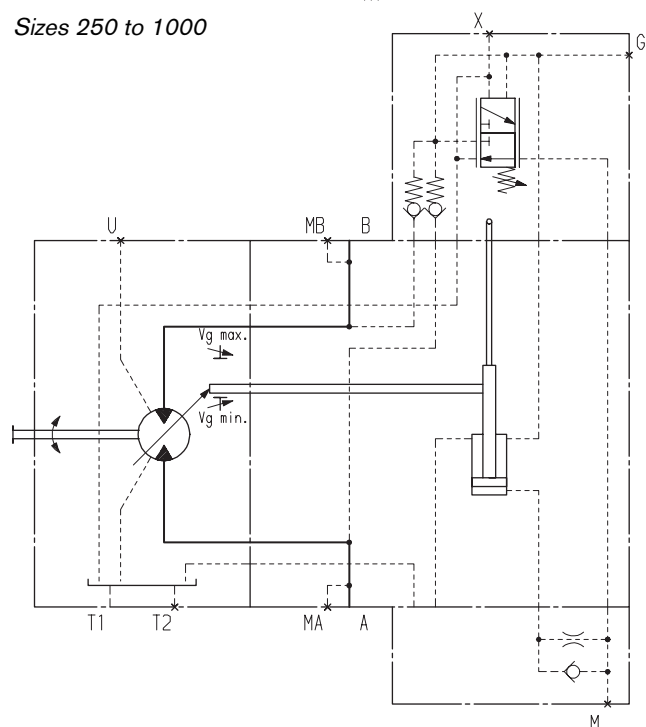

HA - Automatic Control, High-Pressure Dependent

HA2: pressure rise $\Delta p = 100$ bar

A rise in operating pressure of $\Delta p = 100$ bar causes an increase in the displacement from 0 cm^3 to $V_{g \text{ max}}$ (sizes 28 to 200) or from $0.2 V_{g \text{ max}}$ to $V_{g \text{ max}}$ (sizes 250 to 1000).

Start of control, setting range

Sizes 28 to 200 _____ 80 – 350 bar

Sizes 250 to 1000 _____ 80 – 250 bar

Please state the required start of control in plain text when placing your order, e.g.: start of control at 200 bar

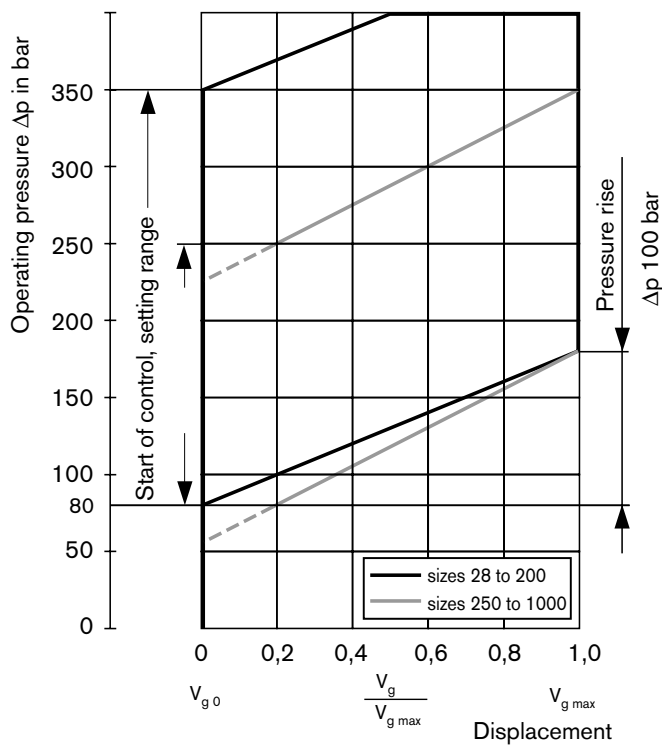

Sizes 28 to 200

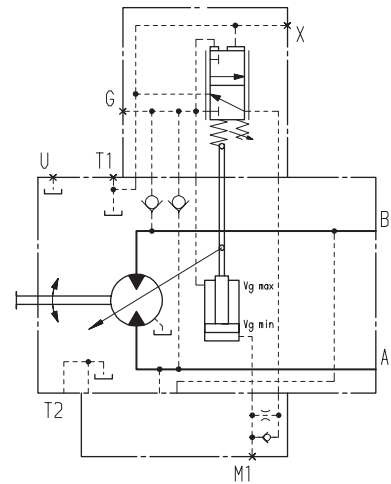

Sizes 250 to 1000

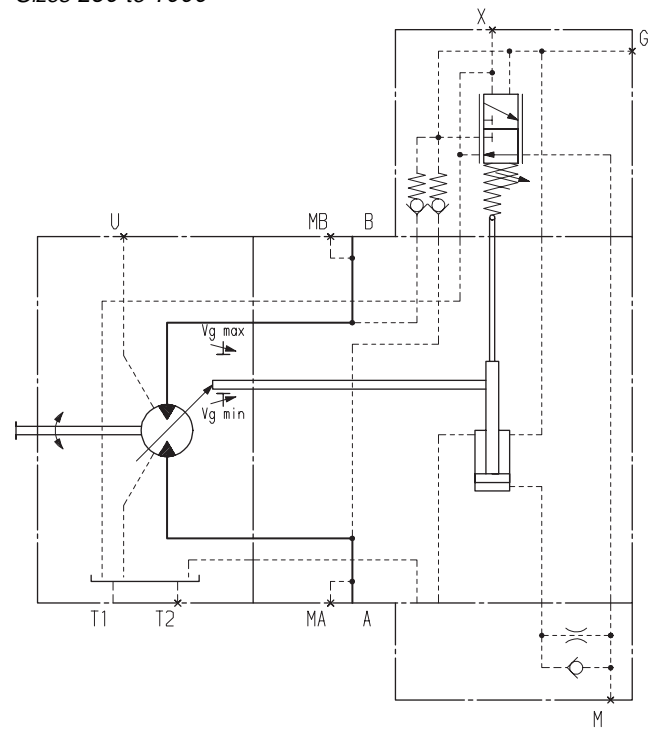

HA - Automatic Control, High-Pressure Dependent (override)

HA.T: Hydraulic override of pressure setpoint

In the case of HA control, the start of control can be influenced by applying a pilot pressure to port X.

For each 1 bar of pilot pressure, the start of control is reduced by 17 bar (sizes 28 to 200) or 8 bar (sizes 250 to 1000).

Examples (sizes 28 to 200):

Start of control setting	300 bar	300 bar
Pilot pressure on port X	0 bar	10 bar
gives start of control at	300 bar	130 bar

If the override is only intended to set the max. displacement (motor swivels to $V_{g \max}$), a maximum pilot pressure of 100 bar is permitted.

Sizes 28 to 200

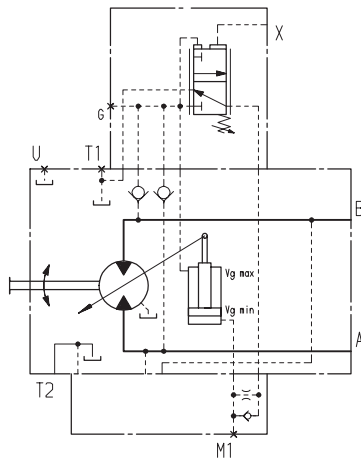

Sizes 250 to 1000

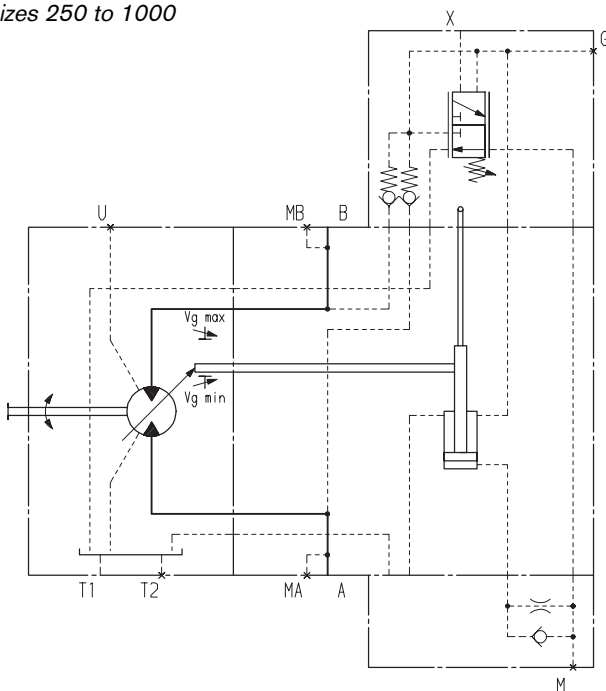

HA.U1, U2: Electrical override of pressure setpoint

With the HA control, high-pressure dependent control can be overridden by an electrical signal on a solenoid. In the case of an override, the variable displacement motor swivels to the maximum swivel angle.

The start of control can be set to between 80 and 300 bar (specify value in plain text when placing your order).

Technical data solenoid b	U1	U2
(electrical override)		
Voltage	12 V ($\pm 20\%$)	24 V ($\pm 20\%$)
No override	de-energized	de-energized
Position at $V_{g \max}$	Current on	Current on
Nominal resistance (at 20°C)	4.8 Ω	19.2 Ω
Nominal output	30 W	30 W
Active current, minimum required	1.5 A	0.75 A
Operating time	100 %	100 %
Degree of protection	see connector design, page 60	

HA1U1, HA1U2: Sizes 28 to 200

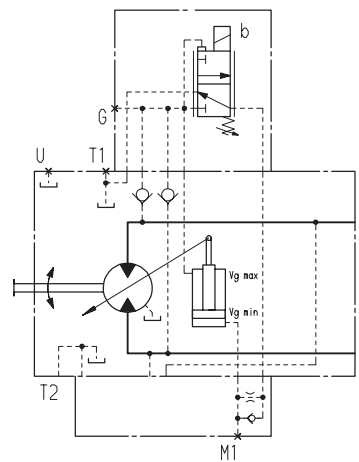

HA2U1, HA2U2: Sizes 28 to 200

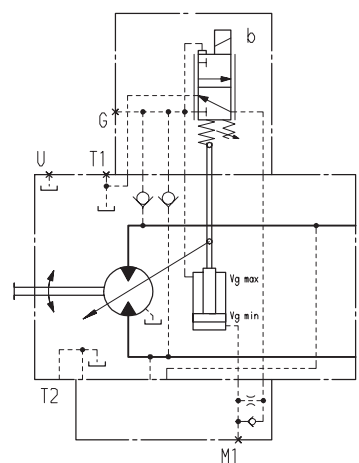

HA - Automatic Control, High-Pressure Dependent (override)

HA.R1, R2: Electrical override of pressure setpoint using electrical travel direction valve

With the HA control, high-pressure dependent control can be overridden by an electrical signal on solenoid b. In the case of an override, the variable displacement motor swivels to the maximum swivel angle.

The travel direction valve ensures that the preselected pressure outlet of the hydraulic motor always controls the swivel angle, even if the high pressure side changes (e.g. during a descent). This therefore prevents an undesirable swiveling of the variable displacement motor to a greater displacement.

Depending on the direction of rotation (direction of travel), the travel direction valve (see page 21) can be actuated through the compression spring or solenoid a.

Technical data, solenoid a (travel direction valve)		R1	R2
Voltage		12 V ($\pm 20\%$)	24 V ($\pm 20\%$)
Direction of rotation	Operating pressure in	Solenoid a	
counter-clockwise	B	actuated	actuated
clockwise	A	de-energized	de-energized
Nominal resistance (at 20°C)		5.5 Ω	21.7 Ω
Nominal output		26.2 W	26.5 W
Active current, minimum required		1.32 A	0.67 A
Operating time		100 %	100 %
Degree of protection		see connector design, page 60	

Technical data, solenoid b (electrical override)		R1	R2
Voltage		12 V ($\pm 20\%$)	24 V ($\pm 20\%$)
No override		de-energized	de-energized
Position at $V_{g \max}$		Current on	Current on
Nominal resistance (at 20°C)		4.8 Ω	19.2 Ω
Nominal output		30 W	30 W
Active current, minimum required		1.5 A	0.75 A
Operating time		100 %	100 %
Degree of protection		see connector design, page 60	

HA1R1, HA1R2: Sizes 28 to 200

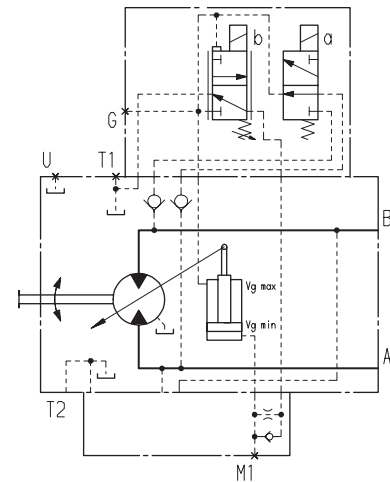

HA2R1, HA2R2: Sizes 28 to 200

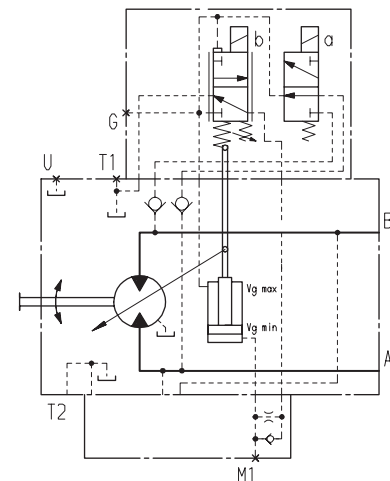

DA - Hydraulic Control, Speed Dependent

The A6VM variable displacement motor with speed-dependent hydraulic control is best used for hydrostatic transmissions in combination with the A4VG variable displacement pump with DA control.

The pilot pressure derived from the driving speed of the A4VG variable displacement pump, together with the operating pressure, regulate the swivel angle of the hydraulic motor.

Increasing driving speed, i.e. rising pilot pressure, causes the motor to swivel to a lower displacement (lower torque, higher speed), depending on the operating pressure.

If the operating pressure rises above the value set on the controller, the motor swivels to a higher displacement (higher torque, lower speed).

The design of a drive with DA control must be carried out using the technical data relating to the A4VG variable displacement pump with DA control.

Detailed Information can be obtained from our sales departments and on the Internet at www.boschrexroth.com/da-control.

Please note:

- The start of control and the DA characteristic are influenced by the pressure in the case. A rise in pressure in the case causes a drop in the start of control and a corresponding parallel movement of the performance curve (see page 5).

DA, DA1, DA4: Hydraulic control, speed dependent with hydraulic travel direction valve

The travel direction valve is operated according to the direction of rotation (direction of travel) using the control pressures X_1 or X_2 .

Direction of rotation	Operating pressure in	Pilot pressure in
clockwise	A	X_1
counter-clockwise	B	X_2

Sizes 28 to 200

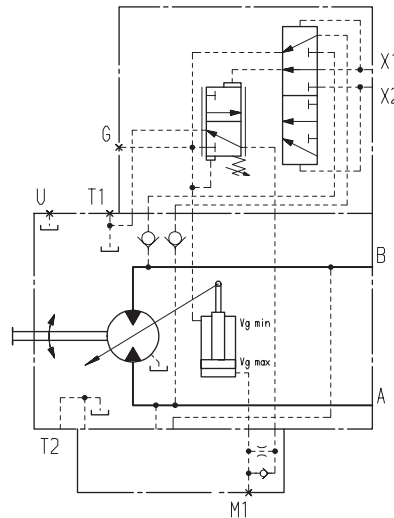

Sizes 250 to 1000

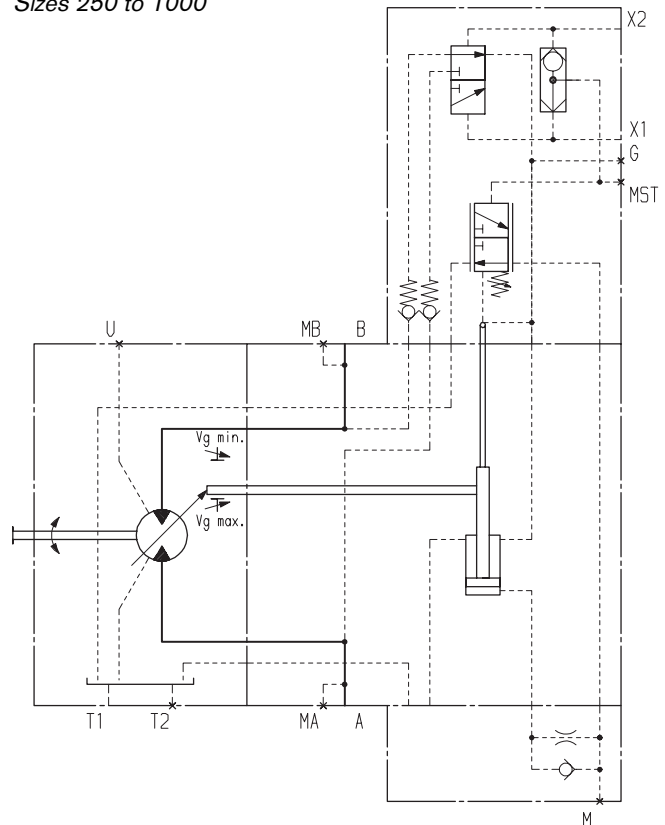

DA - Hydraulic Control, Speed Dependent

DA2, DA3, DA5, DA6: Hydraulic control, speed dependent with electrical travel direction valve + electrical $V_{g \max}$ switch

Depending on the direction of rotation (direction of travel), the travel direction valve can be actuated through the compression spring or solenoid a.

By connecting an electrical current to solenoid b, the controller can be overridden and the motor adjusted to max. displacement (high torque, low speed) (so called "electrical $V_{g \max}$ switch").

Technical data, solenoids a and b	DA2, DA5	DA3, DA6
Voltage	12 V ($\pm 20\%$)	24 V ($\pm 20\%$)
Direction of rotation	Operating pressure in	Solenoid a
counter-clockwise	B	de-energized
clockwise	A	actuated
Nominal resistance (at 20°C)	5.5 Ω	21.7 Ω
Nominal output	26.2 W	26.5 W
Active current, minimum required	1.32 A	0.67 A
Operating time	100 %	100 %
Degree of protection	see connector design, page 60	

Sizes 28 to 200

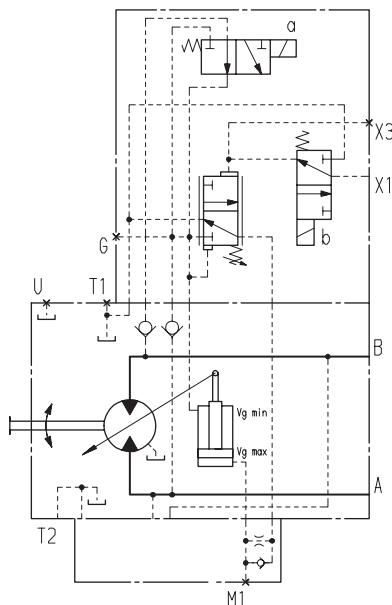

Electrical travel direction valve (for DA, HA.R)

The travel direction valve of the motor is switched using the 4/3 directional-control valve on the control unit of the driving pump. Usually, this provides trouble-free drivability of the driven machine.

However, with unfavorable operating parameters this can lead to undesired conditions (jerky, uncontrolled braking when switching the drive lever into neutral). The reason is that the travel direction valve of the motor operates as soon as the pump is in the neutral position, causing the motor controller to detect a braking pressure, which is then used to control the swivel angle.

To prevent this, the existing switching position on the travel direction valve must be retained while the pump is being put into the neutral position, i.e. an energized valve must remain energized. This can be done using the circuit shown below.

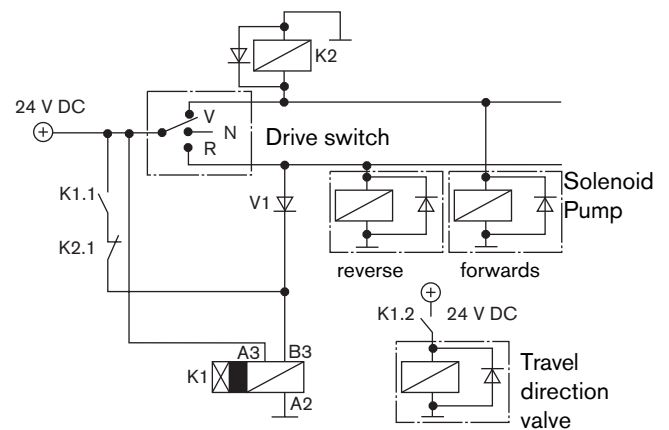

The motor should swivel more slowly than the pump. We therefore recommend that actuation be delayed by approximately 0.8s. This prevents too long a delay when reversing lightweight units.

DA2, DA3, DA5, DA6 control

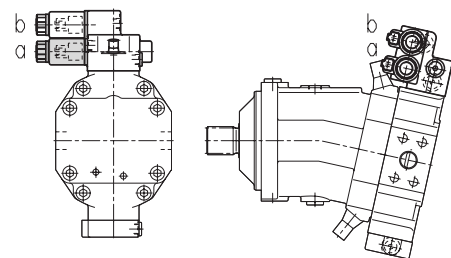

HA1R., HA2R. control (see page 19)

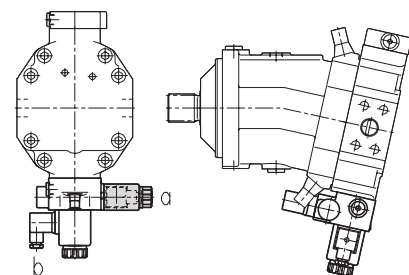

Solenoid a on travel direction valve

Unit Dimensions, Size 28

Before finalizing your design, please request approved installation drawing.

Hydraulic control, pilot pressure dependent HD1, HD2
 Hydraulic two-point control HZ1
 Service line ports A/B lateral, opposite (02)

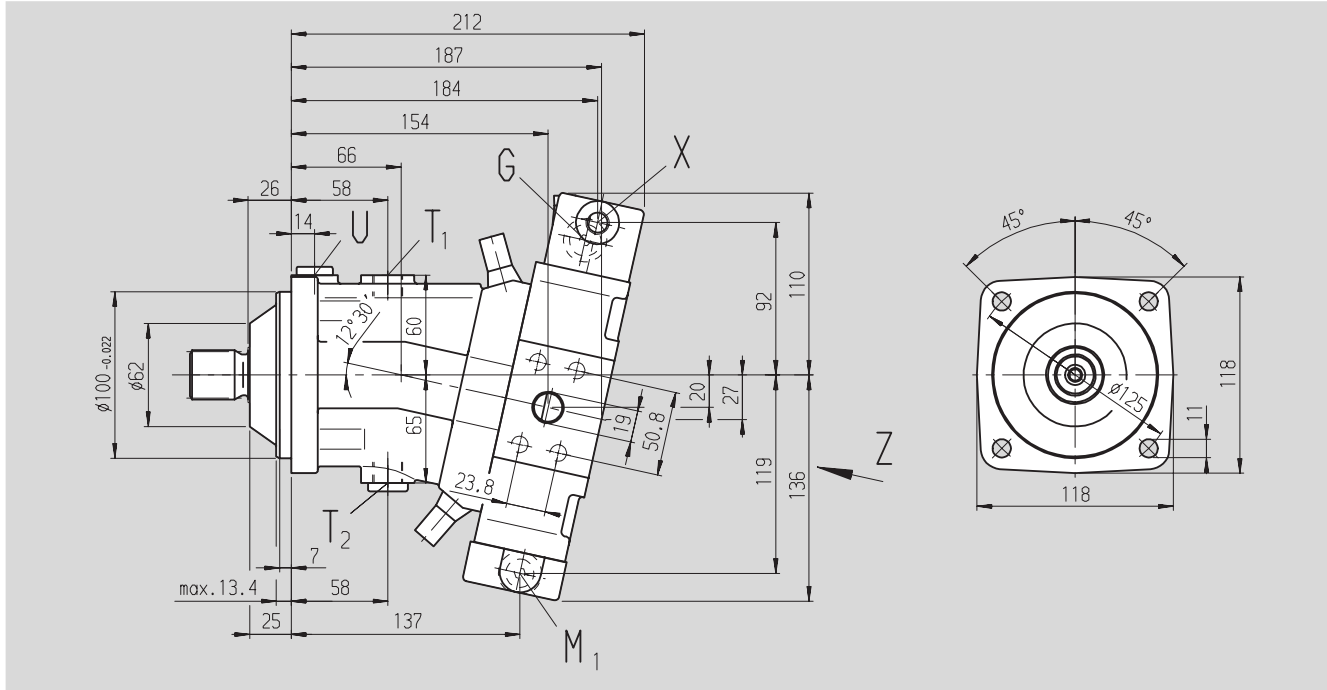

Shaft ends

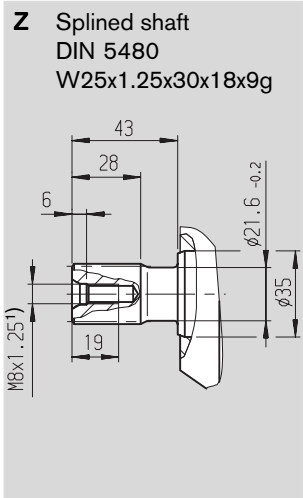
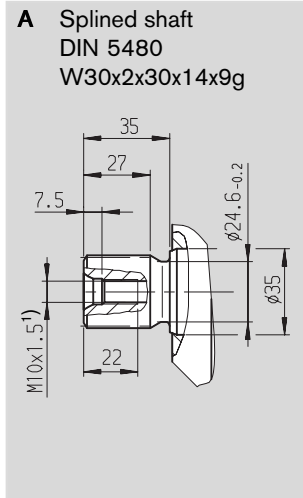

1) DIN 332 center hole

View Z
 Service line ports A/B lateral,
 opposite (02)

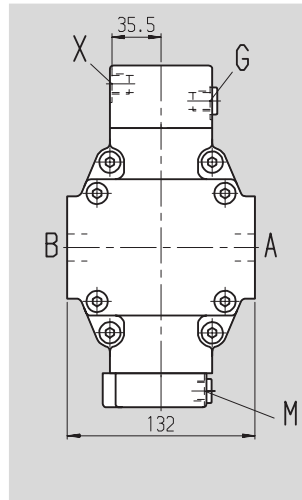

Service line ports A/B
 at rear (01)

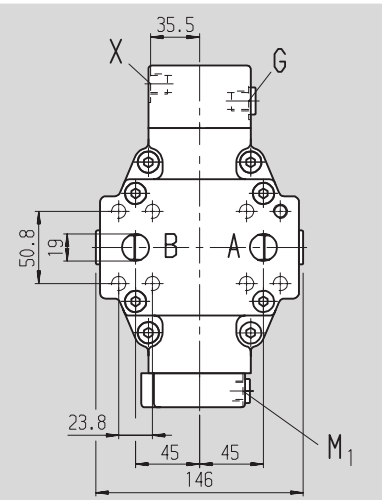

Ports

- A, B Service line ports (high pressure series)
Threaded fitting A/B
- T₁ Leakage-fuel port
- T₂ Leakage fluid/oil drain ²⁾
- X, X₁, X₃ Pilot pressure port
- G Port for synchronous control of several units and for remote charge pressure ²⁾
- G₂ Port for 2nd pressure setting ²⁾
- U Flow port ²⁾
- M₁ Measuring port for charge pressure ²⁾

- SAE J518, 3/4 in
- DIN 13 M10x1.5; 17 deep
- DIN 3852 M18x1.5; 12 deep
- DIN 3852 M18x1.5; 12 deep
- DIN 3852 M14x1.5; 12 deep
- DIN 3852 M14x1.5; 12 deep
- DIN 3852 M14x1.5; 12 deep
- DIN 3852 M16x1.5; 12 deep
- DIN 3852 M14x1.5; 12 deep

Tightening torque, max

- see safety instructions
- 140 Nm
- 140 Nm
- 80 Nm
- 80 Nm
- 80 Nm
- 100 Nm
- 80 Nm

²⁾ closed

Unit Dimensions, Size 28

Before finalizing your design, please request approved installation drawing.

Hydraulic control, pilot pressure dependent, with pressure control, direct HD.D

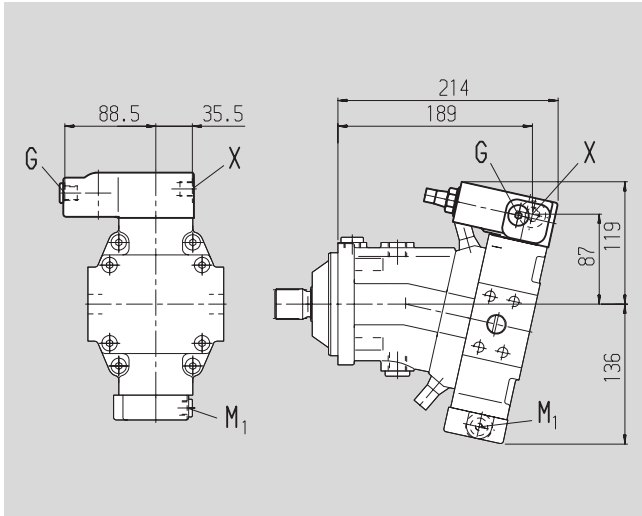

Hydraulic control, pilot pressure dependent, with pressure control, direct and 2nd pressure setting HD.E

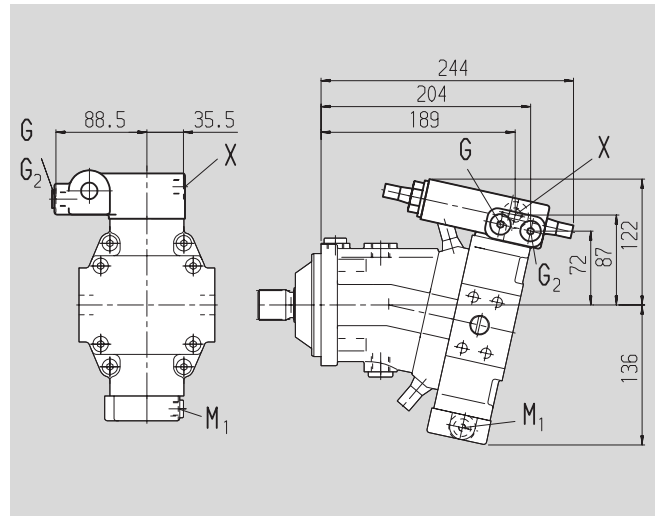

Electrical control with proportional solenoid EP1, EP2

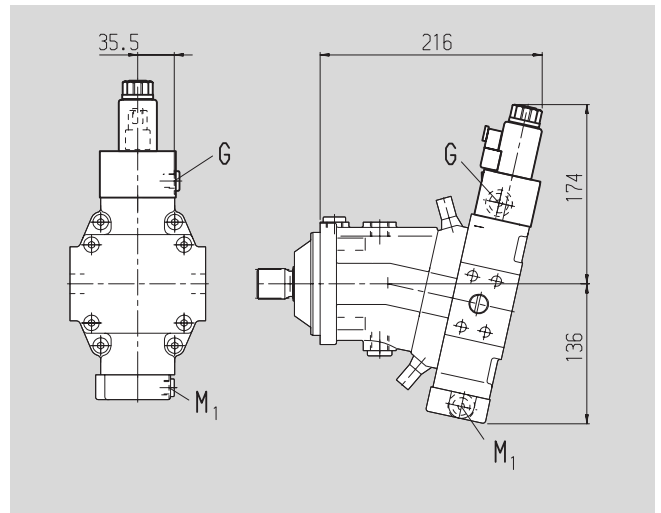

Electrical control (proportional solenoid) with pressure control, direct EP.D

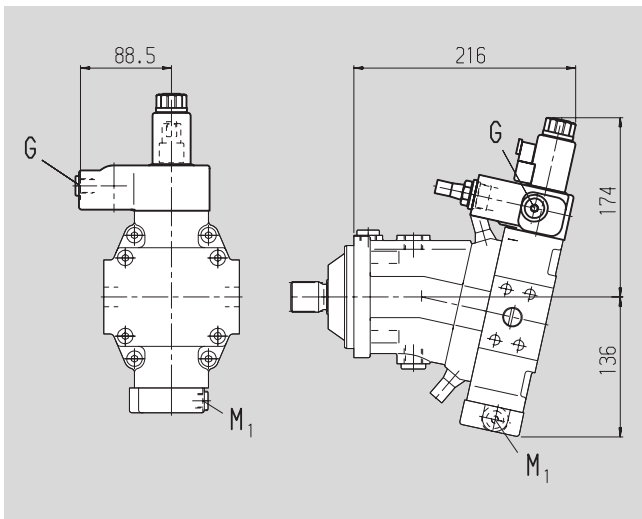

Electrical control (proportional solenoid) with pressure control, direct and 2nd pressure setting EP.E

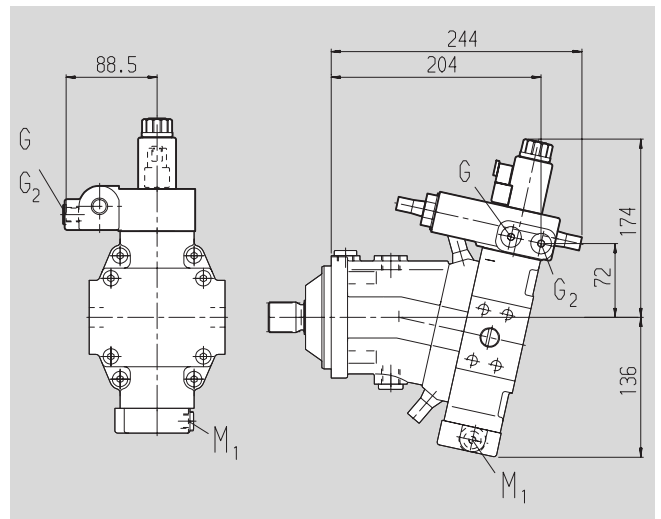

Unit Dimensions, Size 28

Before finalizing your design, please request approved installation drawing.

Electrical two-point control with solenoid EZ1, EZ2

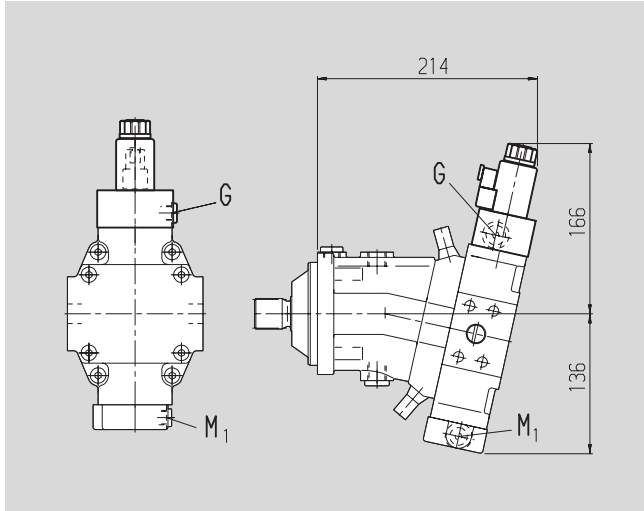

Automatic control, high-pressure dependent and electric override HA1U1, HA2U2

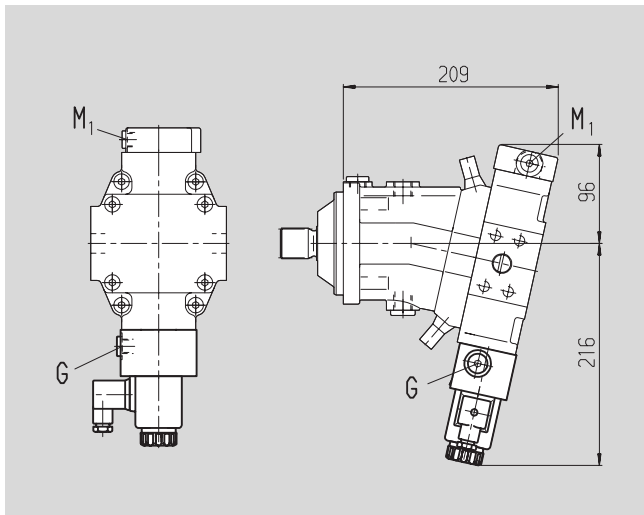

Hydraulic control, speed dependent and hydraulic travel direction valve DA1, DA4

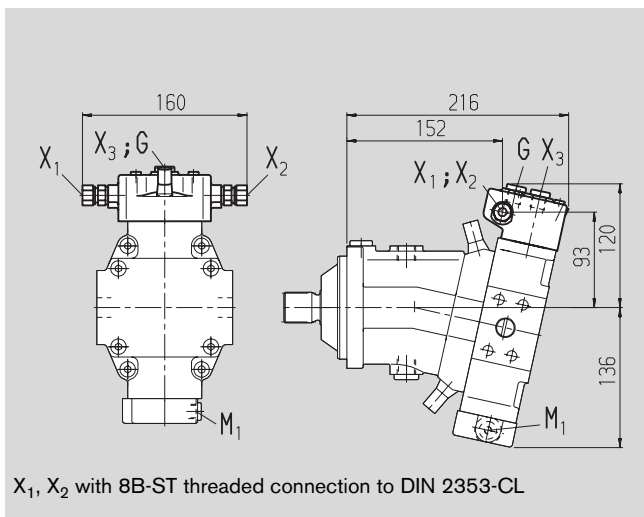

X₁, X₂ with 8B-ST threaded connection to DIN 2353-CL

Automatic control, high-pressure dependent HA1, HA2, and hydraulic override HA1T, HA2T

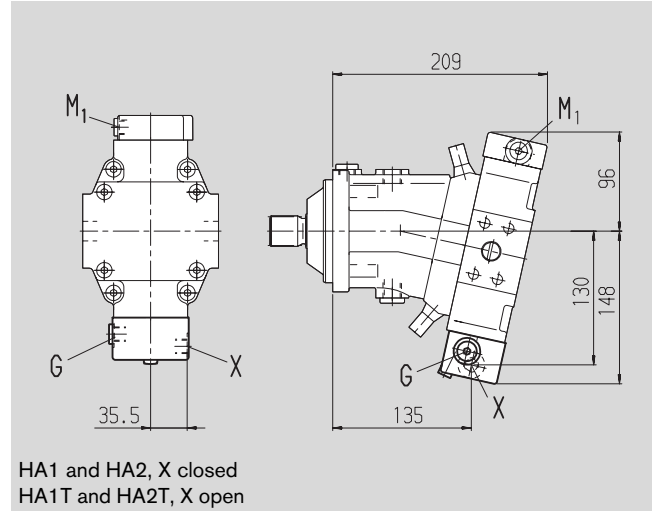

HA1 and HA2, X closed
HA1T and HA2T, X open

Automatic control, high-pressure dependent, electric override and elec. travel direction valve HA1R1, HA2R2

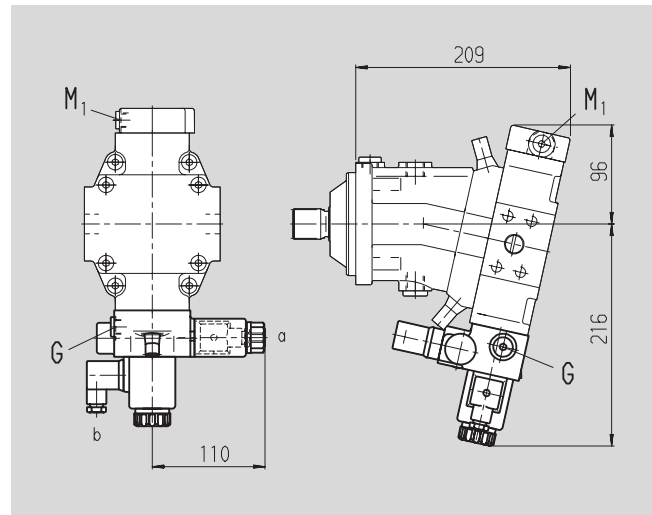

Hydraulic control, speed dependent, elec. travel direction valve and elec. V_{g max} switch DA2, DA3, DA5, DA6

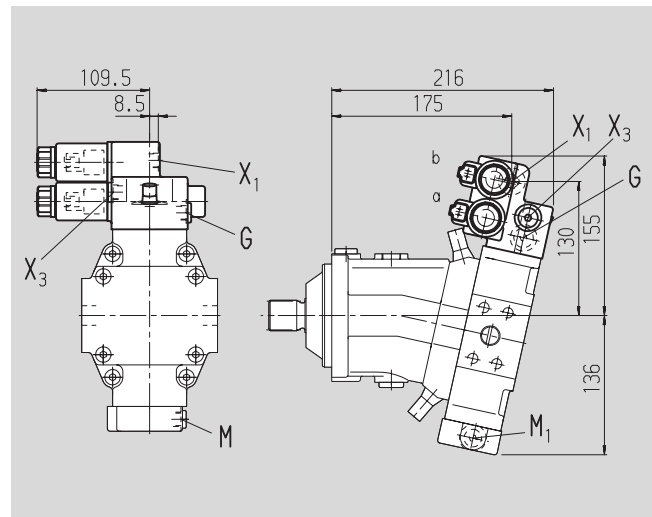

Unit Dimensions, Size 55

Before finalizing your design, please request approved installation drawing.

Hydraulic control, pilot pressure dependent HD1, HD2
 Hydraulic two-point control HZ3
 Service line ports A/B lateral, opposite (02)

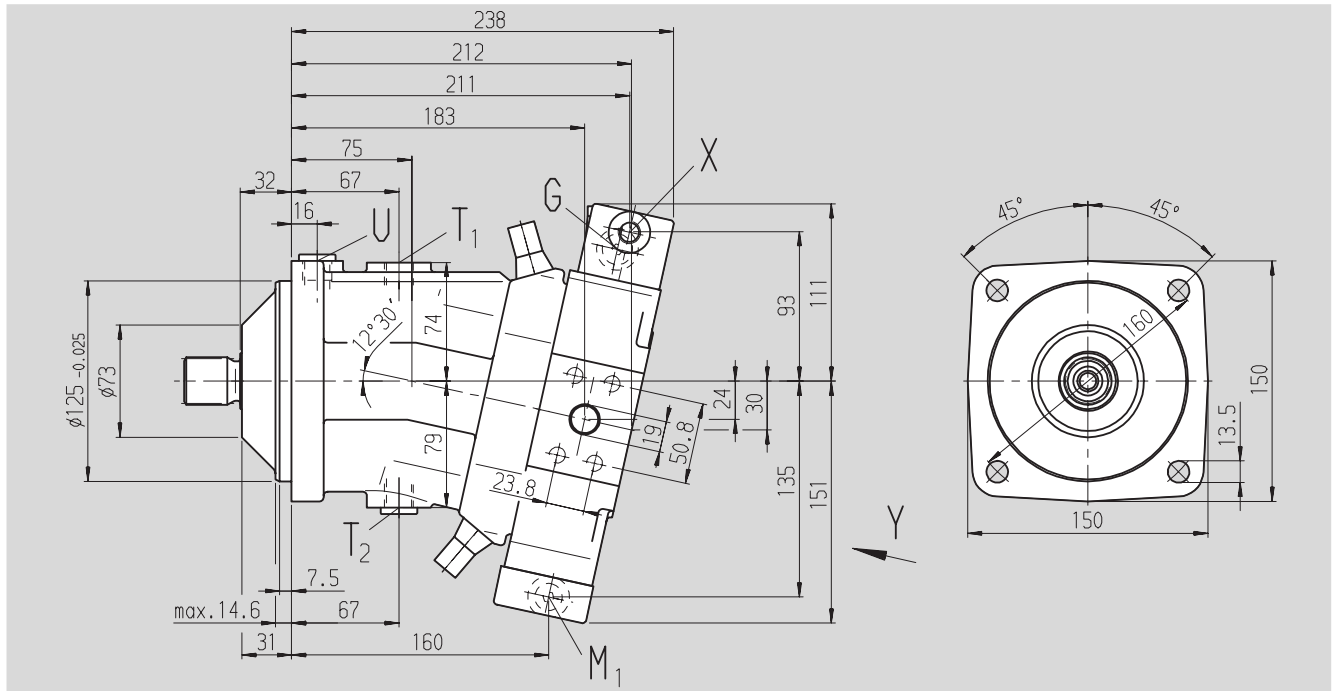

View Z

Shaft ends

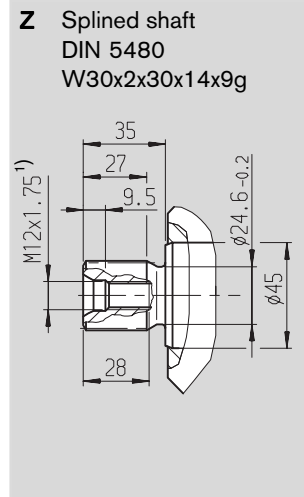
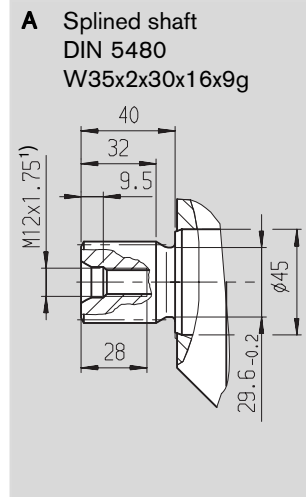

¹⁾ DIN 332 center hole

Service line ports A/B lateral, opposite (02)

Service line ports A/B at rear (01)

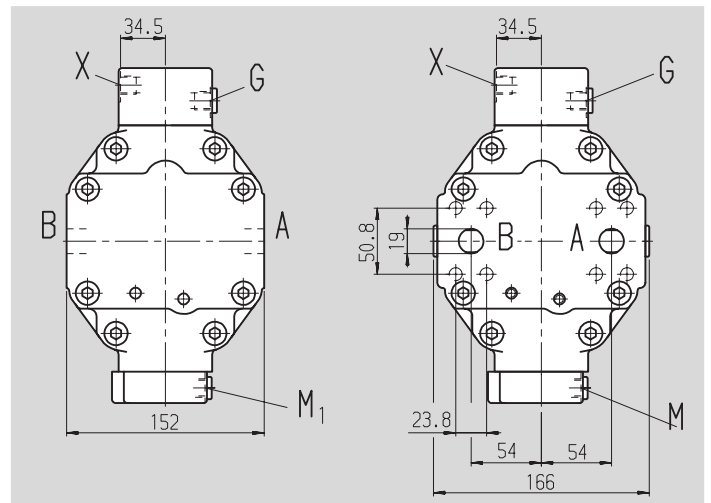

Ports

- A, B Service line port (high pressure series)
Threaded fitting A/B
- T₁ Leakage-fuel port
- T₂ Leakage fluid/oil drain ²⁾
- X, X₁, X₃ Pilot pressure port
- G Port for synchronous control of several units and for remote charge pressure ²⁾
- G₂ Port for 2nd pressure setting ²⁾
- U Flow port ²⁾
- M₁ Measuring port for charge pressure ²⁾

- SAE J518, 3/4 in
- DIN 13 M10x1.5; 17 deep
- DIN 3852 M18x1.5; 12 deep
- DIN 3852 M18x1.5; 12 deep
- DIN 3852 M14x1.5; 12 deep
- DIN 3852 M14x1.5; 12 deep
- DIN 3852 M14x1.5; 12 deep
- DIN 3852 M14x1.5; 12 deep
- DIN 3852 M14x1.5; 12 deep
- DIN 3852 M14x1.5; 12 deep

Tightening torque, max

- see safety instructions
- 140 Nm
- 140 Nm
- 80 Nm
- 80 Nm
- 80 Nm
- 80 Nm
- 80 Nm
- 80 Nm
- 80 Nm

²⁾ closed

Unit Dimensions, Size 55

Before finalizing your design, please request approved installation drawing.

Hydraulic control, pilot pressure dependent, with pressure control, direct HD.D

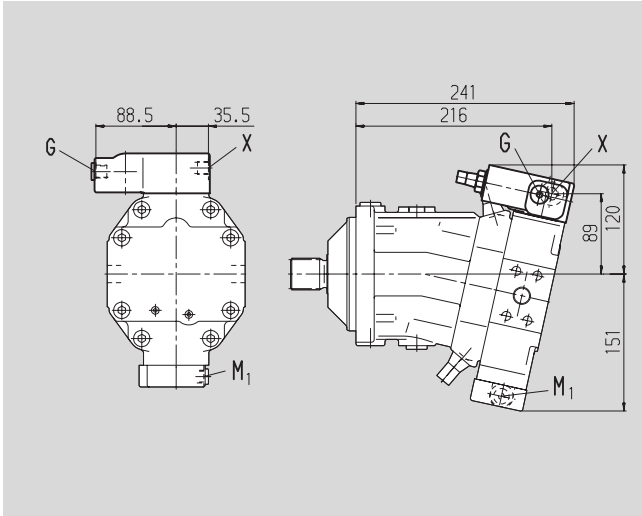

Hydraulic control, pilot pressure dependent, with pressure control, direct and 2nd pressure setting HD.E

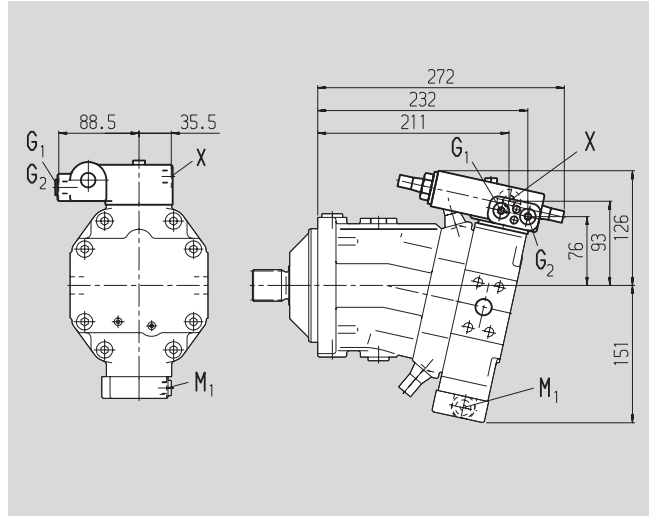

Hydraulic control HZ3

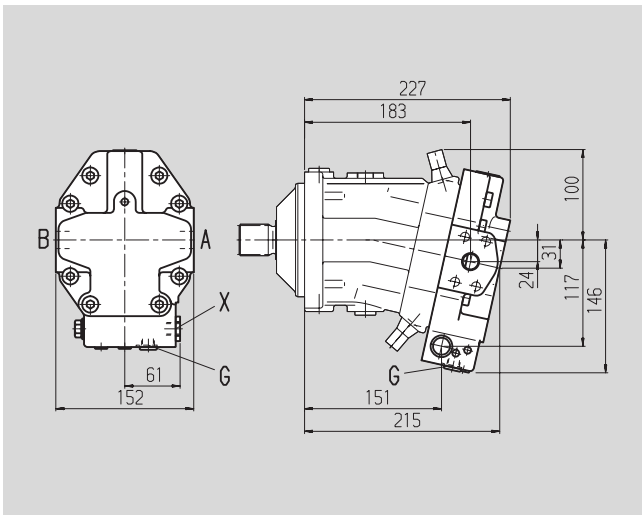

Electrical control with proportional solenoid EP1, EP2

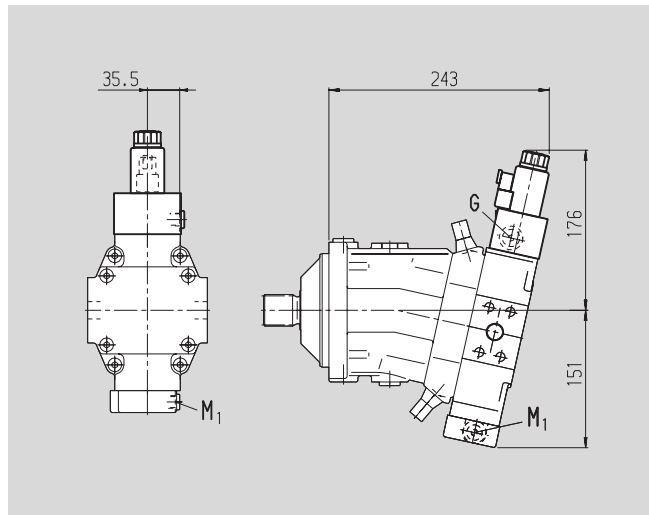

Electrical control (proportional solenoid) with pressure control, direct EP.D

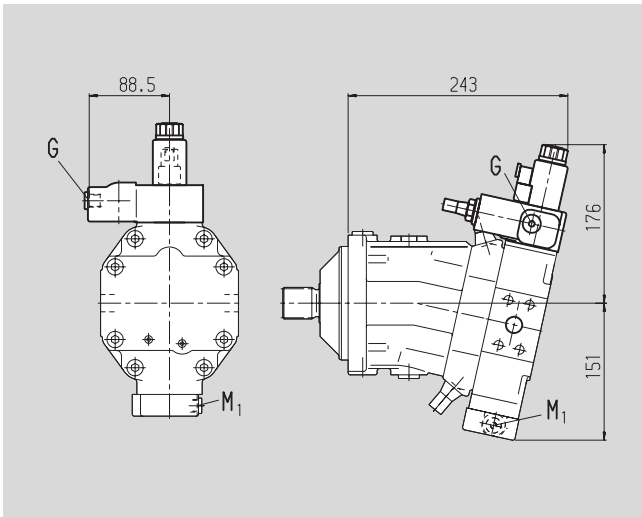

Electrical control (proportional solenoid) with pressure control, direct and 2nd pressure setting EP.E

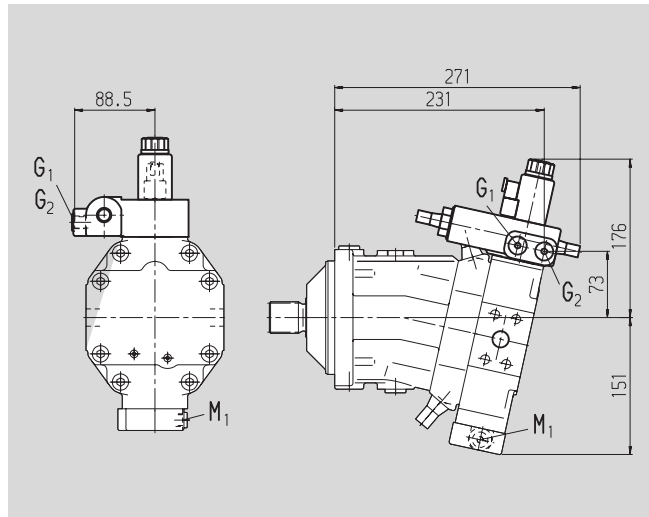

Unit Dimensions, Size 55

Before finalizing your design, please request approved installation drawing.

Electrical two-point control with solenoid EZ3, EZ4

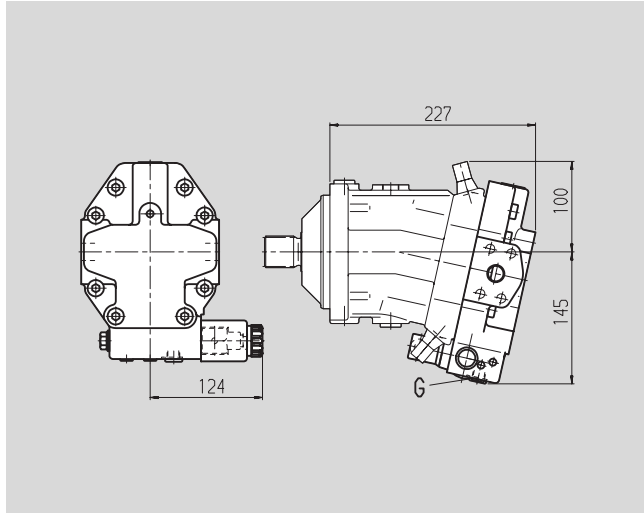

Automatic control, high-pressure dependent and electric override HA1U1, HA2U2

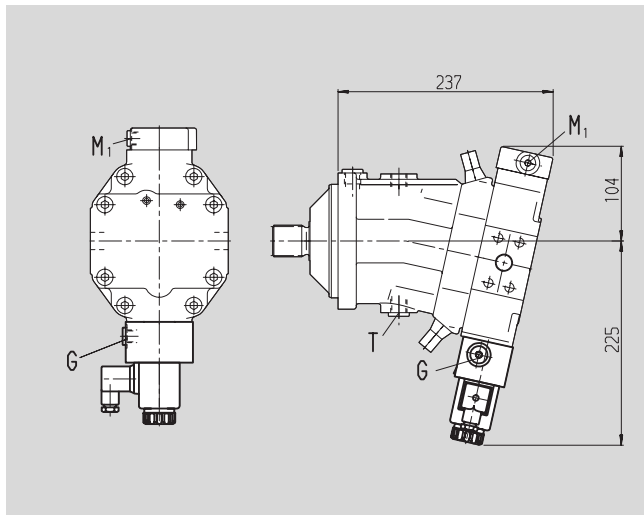

Hydraulic control, speed dependent and hydraulic travel direction valve DA1, DA4

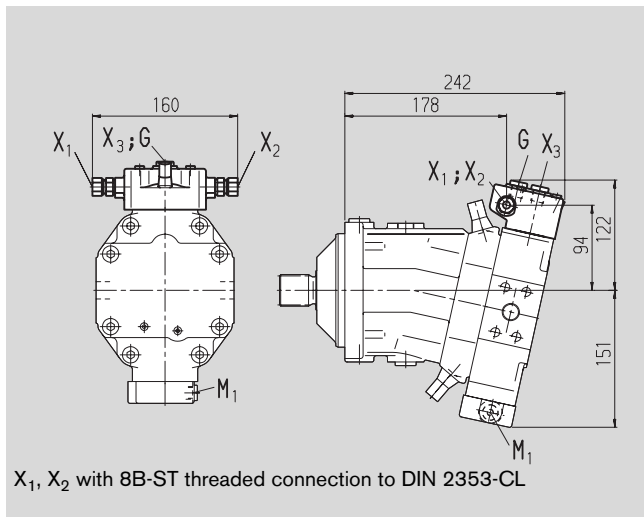

X₁, X₂ with 8B-ST threaded connection to DIN 2353-CL

Automatic control, high-pressure dependent HA1, HA2, and hydraulic override HA1T, HA2T

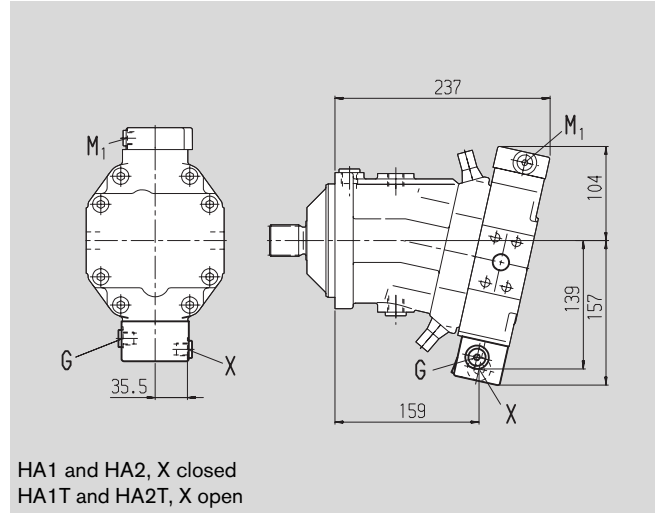

HA1 and HA2, X closed
HA1T and HA2T, X open

Automatic control, high-pressure dependent, electric override and elec. travel direction valve HA1R1, HA2R2

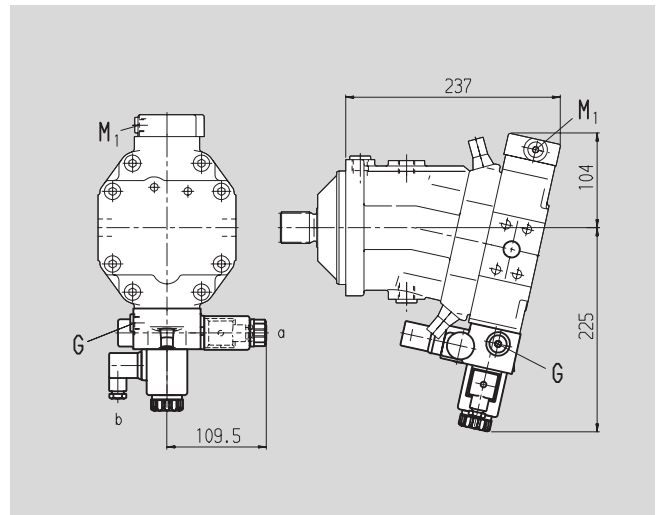

Hydraulic control, speed dependent, elec. travel direction valve and elec. V_{g max} switch DA2, DA3, DA5, DA6

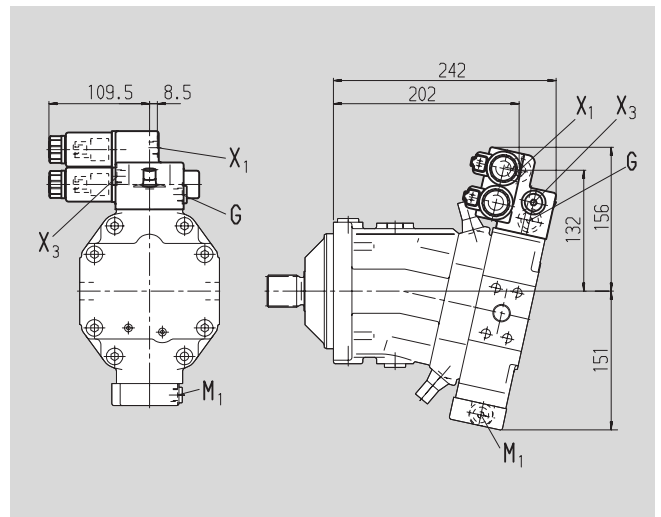

Unit Dimensions, Size 80

Before finalizing your design, please request approved installation drawing.

Hydraulic control, pilot pressure dependent HD1, HD2
 Hydraulic two-point control HZ3
 Service line ports A/B lateral, opposite (02)

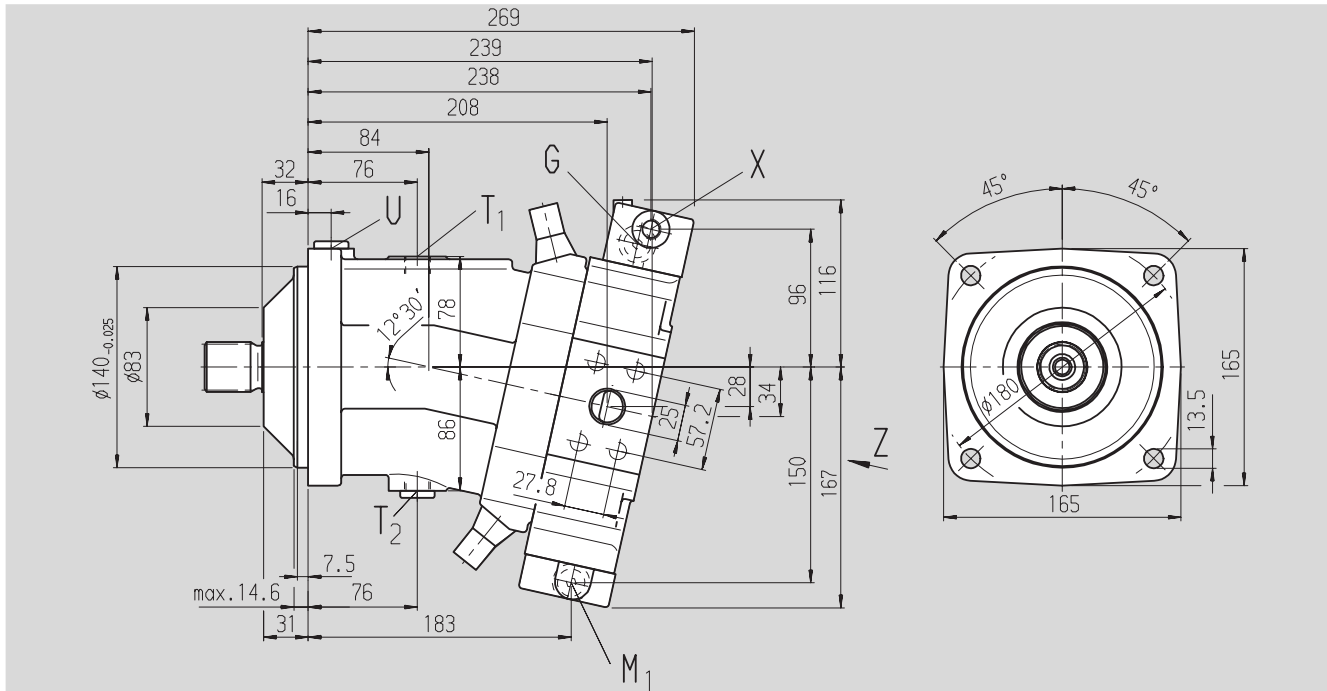

Shaft ends

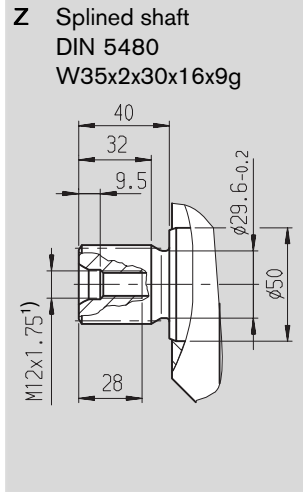
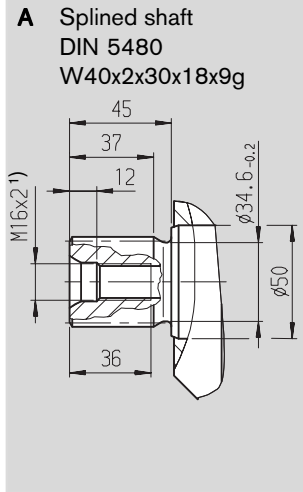

1) DIN 332 center hole

View Z
 Service line ports A/B lateral, opposite (02)

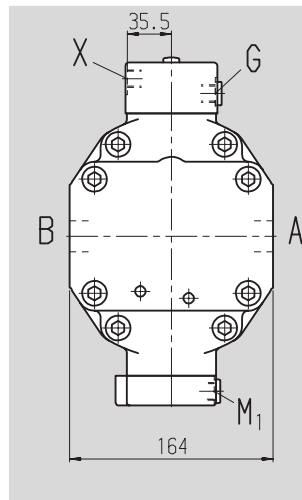

Service line ports A/B at rear (01)

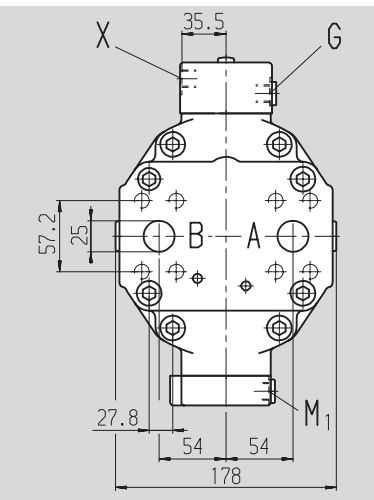

Ports

- A, B Service line port (high pressure series)
Threaded fitting A/B
- T₁ Leakage-fuel port
- T₂ Leakage fluid/oil drain ²⁾
- X, X₁, X₃ Pilot pressure port
- G Port for synchronous control of several units and for remote charge pressure ²⁾
- G₂ Port for 2nd pressure setting ²⁾
- U Flow port ²⁾
- M₁ Measuring port for charge pressure ²⁾

SAE J518, DIN 13	1 in
DIN 3852	M12x1.75; 17 deep
DIN 3852	M18x1.5; 12 deep
DIN 3852	M18x1.5; 12 deep
DIN 3852	M14x1.5; 12 deep
DIN 3852	M14x1.5; 12 deep
DIN 3852	M14x1.5; 12 deep
DIN 3852	M14x1.5; 12 deep
DIN 3852	M14x1.5; 12 deep
DIN 3852	M14x1.5; 12 deep

Tightening torque, max

see safety instructions
140 Nm
140 Nm
80 Nm
80 Nm
80 Nm
80 Nm
140 Nm
80 Nm

²⁾ closed

Unit Dimensions, Size 80

Before finalizing your design, please request approved installation drawing.

Hydraulic control, pilot pressure dependent, with pressure control, direct HD.D

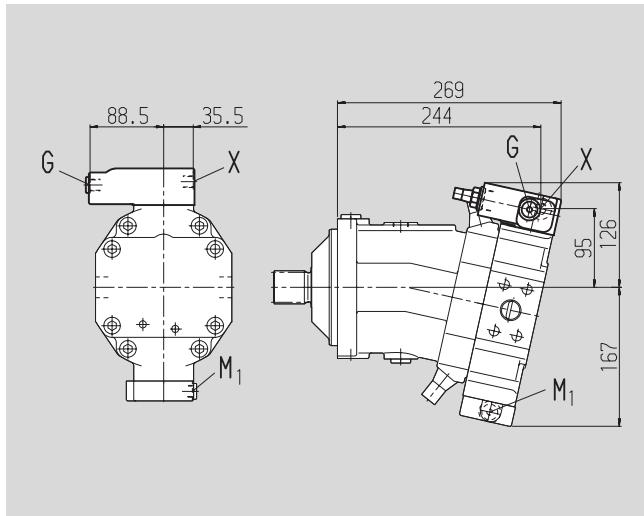

Hydraulic control, pilot pressure dependent, with pressure control, direct and 2nd pressure setting HD.E

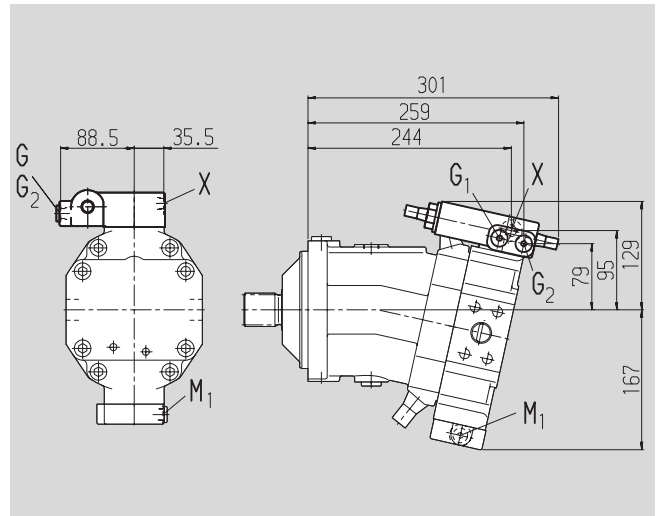

Hydraulic control HZ3

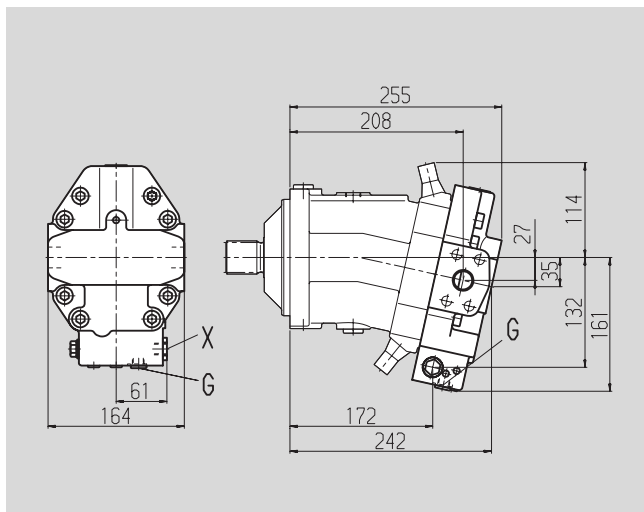

Electrical control with proportional solenoid EP1, EP2

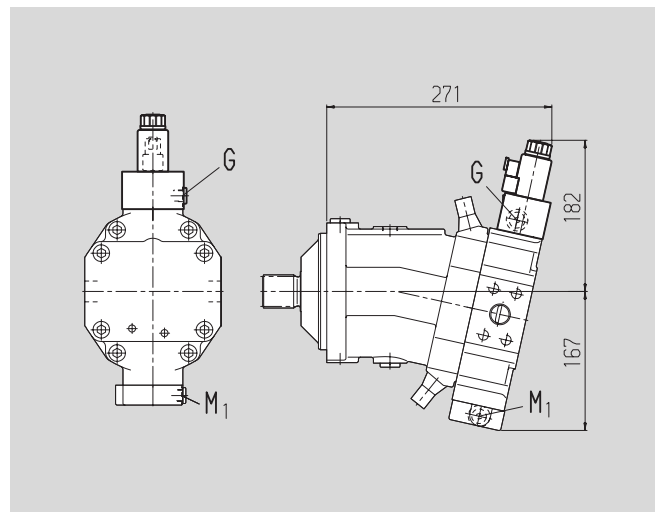

Electrical control (proportional solenoid) with pressure control, direct EP.D

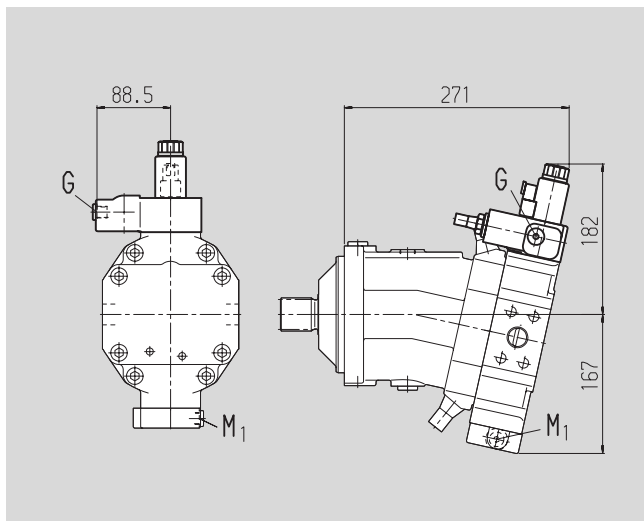

Electrical control (proportional solenoid) with pressure control, direct and 2nd pressure setting EP.E

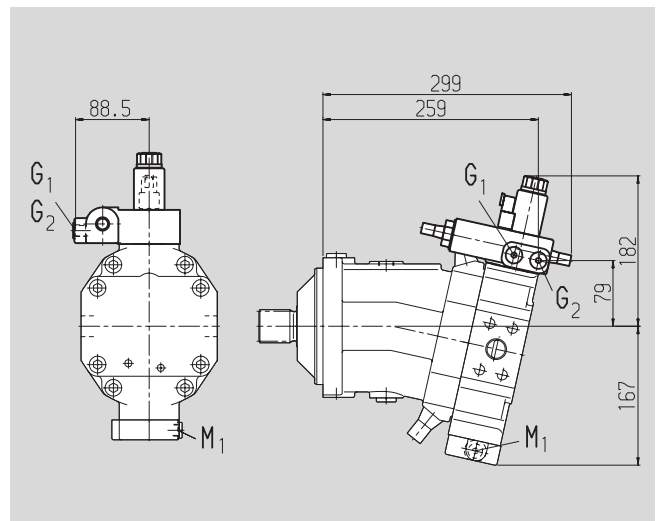

Unit Dimensions, Size 80

Before finalizing your design, please request approved installation drawing.

Electrical two-point control with solenoid EZ3, EZ4

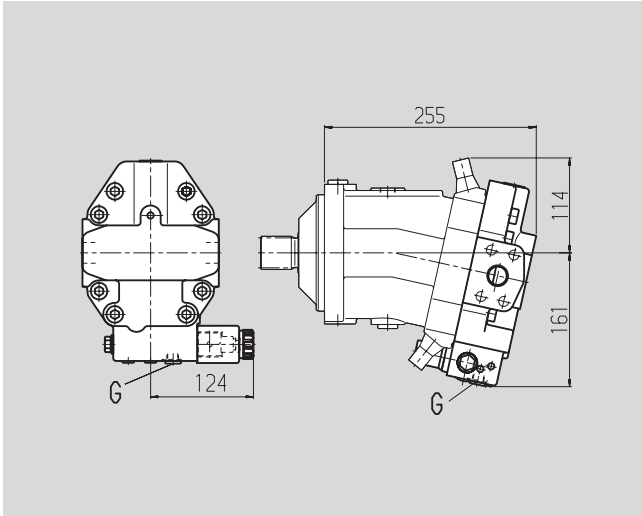

Automatic control, high-pressure dependent and electric override HA1U1, HA2U2

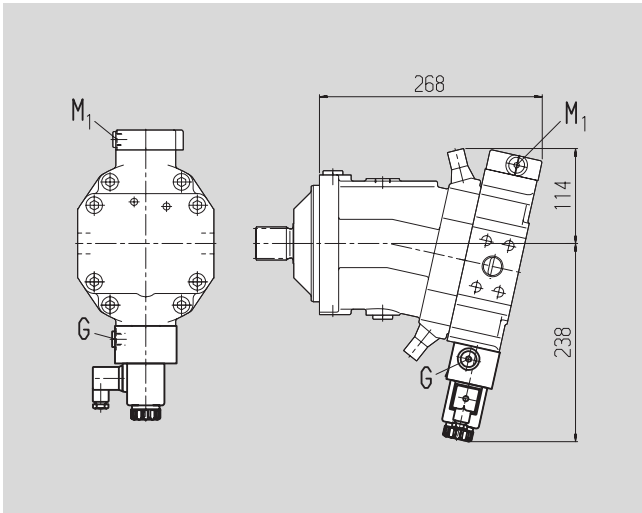

Hydraulic control, speed dependent and hydraulic travel direction valve DA1, DA4

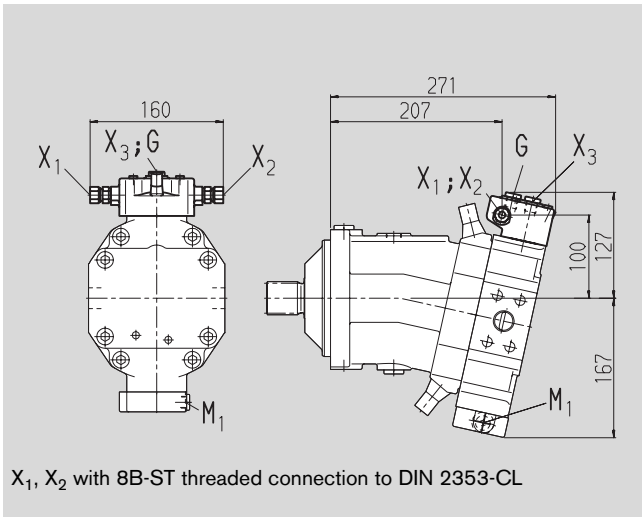

X₁, X₂ with 8B-ST threaded connection to DIN 2353-CL

Automatic control, high-pressure dependent HA1, HA2, and hydraulic override HA1T, HA2T

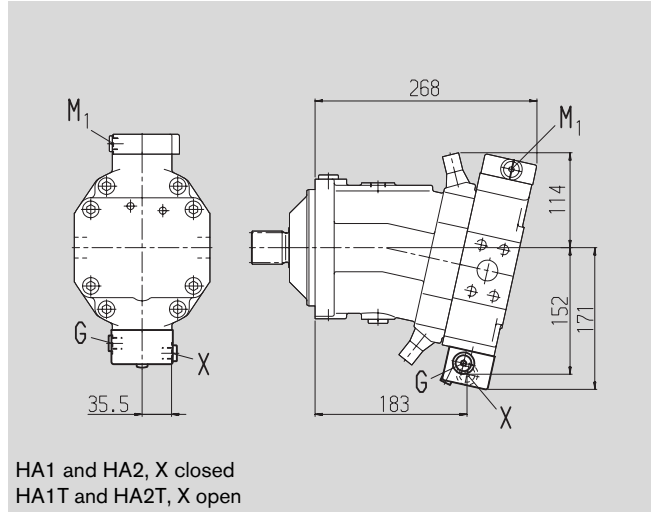

HA1 and HA2, X closed
HA1T and HA2T, X open

Automatic control, high-pressure dependent, electric override and elec. travel direction valve HA1R1, HA2R2

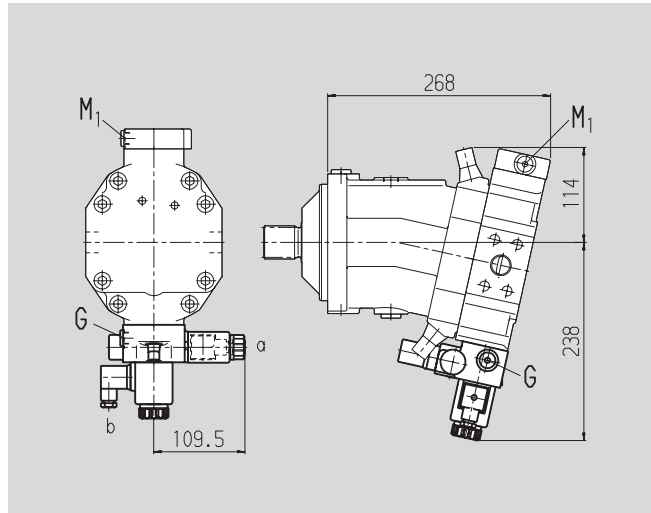

Hydraulic control, speed dependent, elec. travel direction valve and elec. V_{g max} switch DA2, DA3, DA5, DA6

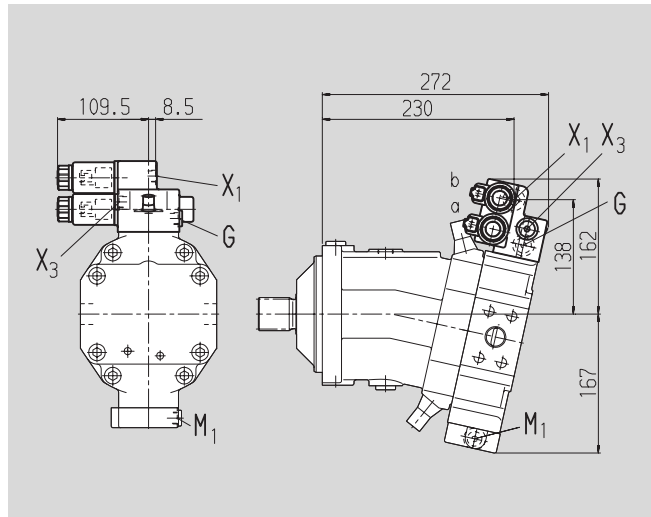

Unit Dimensions, Size 107

Before finalizing your design, please request approved installation drawing.

Hydraulic control, pilot pressure dependent HD1, HD2
 Hydraulic two-point control HZ3
 Service line ports A/B lateral, opposite (02)

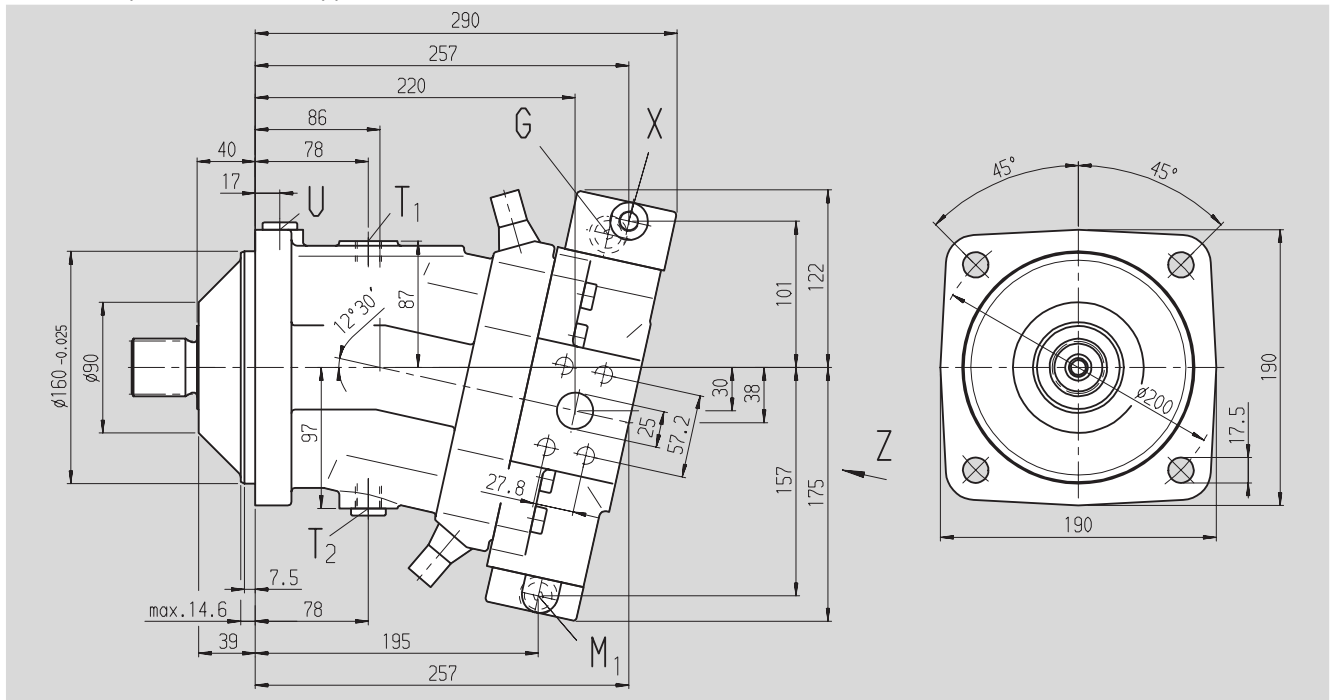

View Z

Shaft ends

A Splined shaft
 DIN 5480
 W45x2x30x21x9g

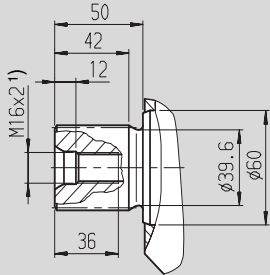

Z Splined shaft
 DIN 5480
 W40x2x30x18x9g

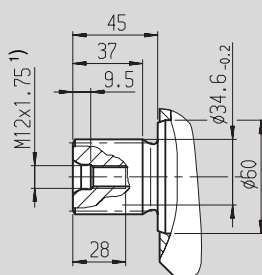

1) DIN 332 center hole

Service line ports A/B lateral, opposite (02)

Service line ports A/B at rear (01)

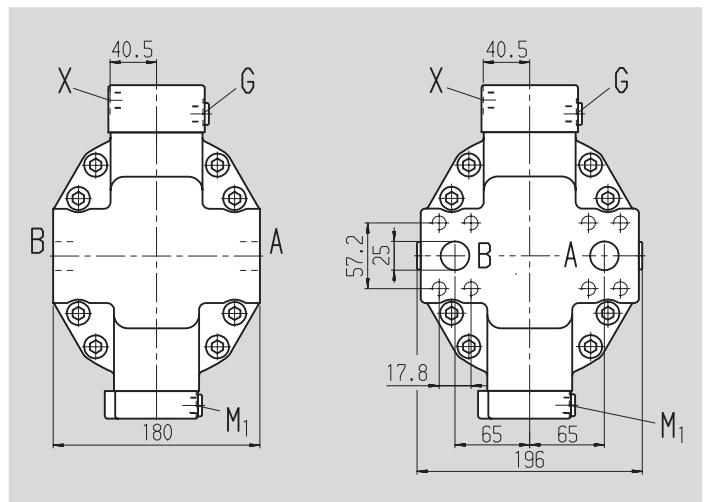

Ports

A, B	Service line port (high pressure series) Threaded fitting A/B
T ₁	Leakage-fuel port
T ₂	Leakage fluid/oil drain ²⁾
X, X ₁ , X ₃	Pilot pressure port
G	Port for synchronous control of several units and for remote charge pressure ²⁾
G ₂	Port for 2nd pressure setting ²⁾
U	Flow port ²⁾
M ₁	Measuring port for charge pressure ²⁾

SAE J518,
DIN 13
DIN 3852
DIN 3852
DIN 3852
DIN 3852
DIN 3852
DIN 3852
DIN 3852

1 in
M12x1.75; 17 deep
M18x1.5; 12 deep
M18x1.5; 12 deep
M14x1.5; 12 deep
M14x1.5; 12 deep
M14x1.5; 12 deep
M14x1.5; 12 deep
M14x1.5; 12 deep
M14x1.5; 12 deep

Tightening torque, max

see safety instructions
140 Nm
140 Nm
80 Nm
80 Nm

²⁾ closed

Unit Dimensions, Size 107

Before finalizing your design, please request approved installation drawing.

Hydraulic control, pilot pressure dependent, with pressure control, direct HD.D

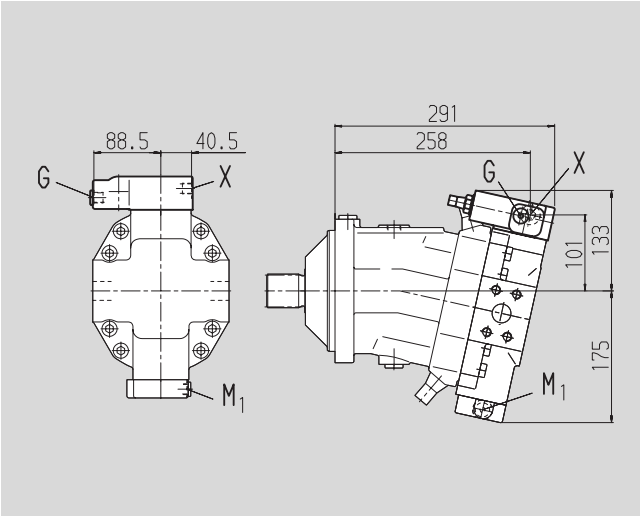

Hydraulic control, pilot pressure dependent, with pressure control, direct and 2nd pressure setting HD.E

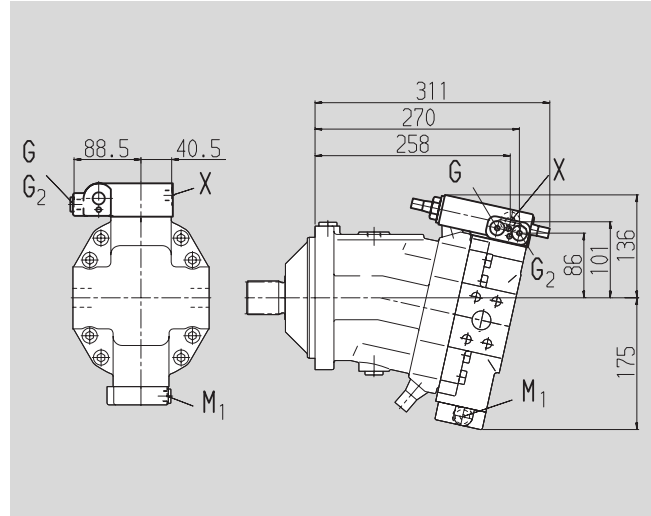

Hydraulic control HZ3

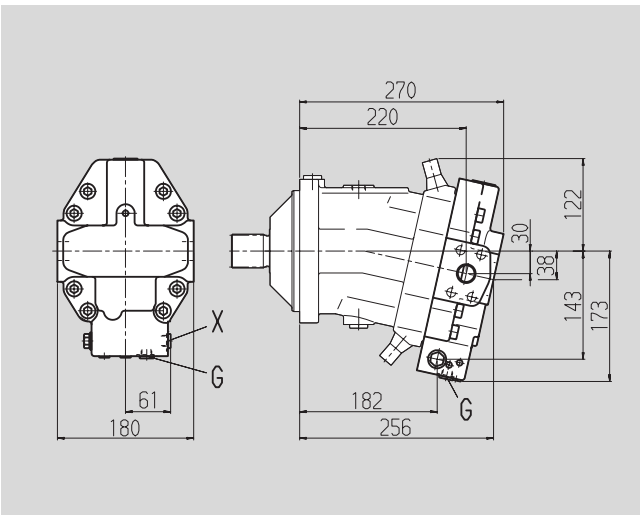

Electrical control with proportional solenoid EP1, EP2

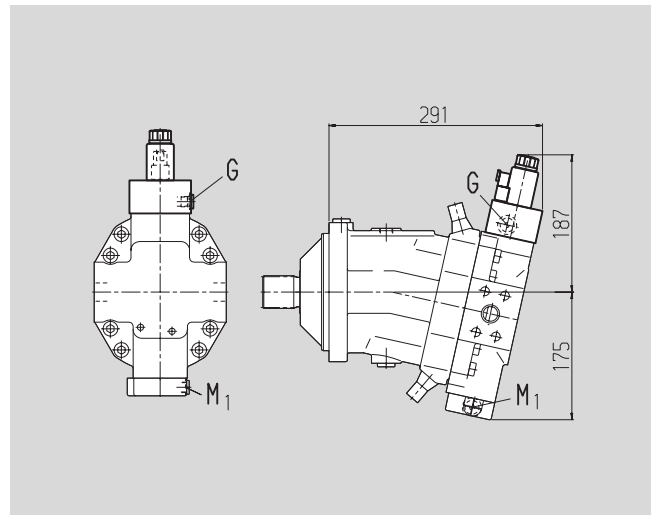

Electrical control (proportional solenoid) with pressure control, direct EP.D

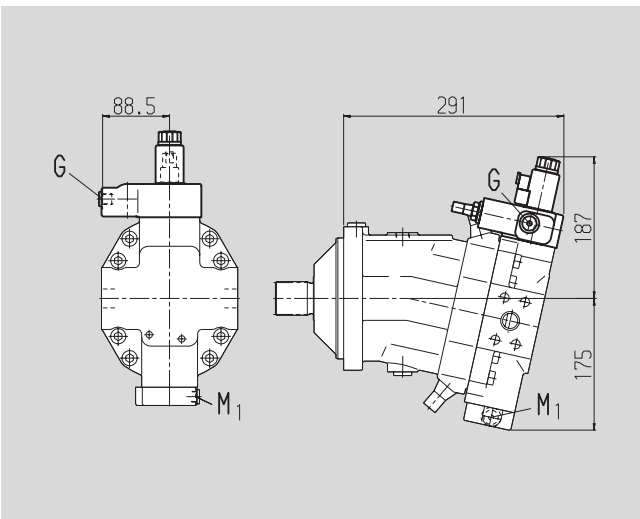

Electrical control (proportional solenoid) with pressure control, direct and 2nd pressure setting EP.E

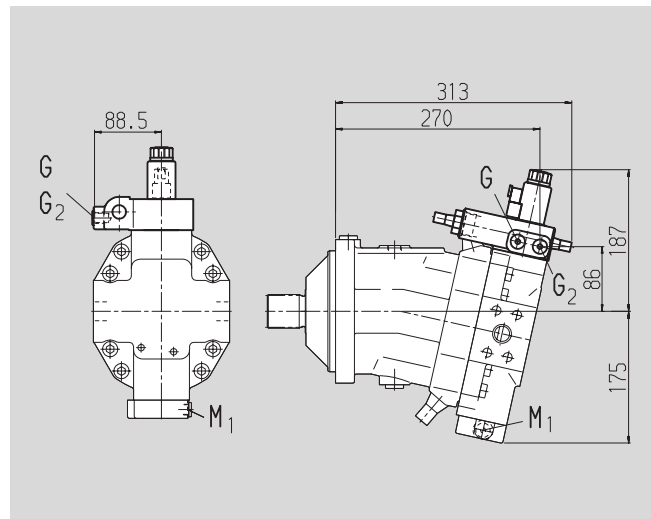

Unit Dimensions, Size 107

Before finalizing your design, please request approved installation drawing.

Electrical two-point control with solenoid EZ3, EZ4

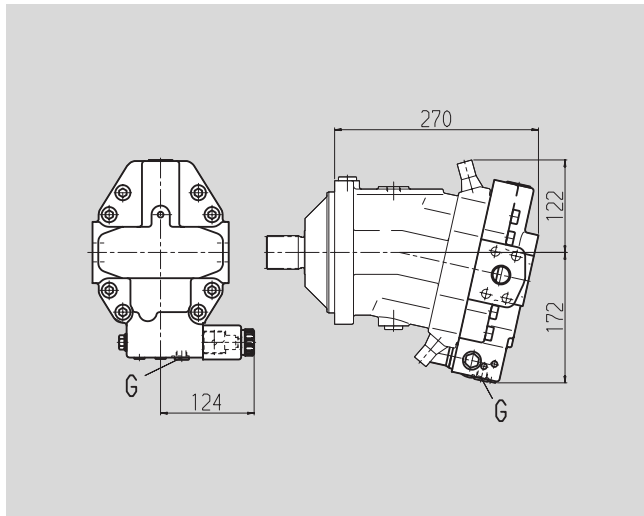

Automatic control, high-pressure dependent HA1, HA2, and hydraulic override HA1T, HA2T

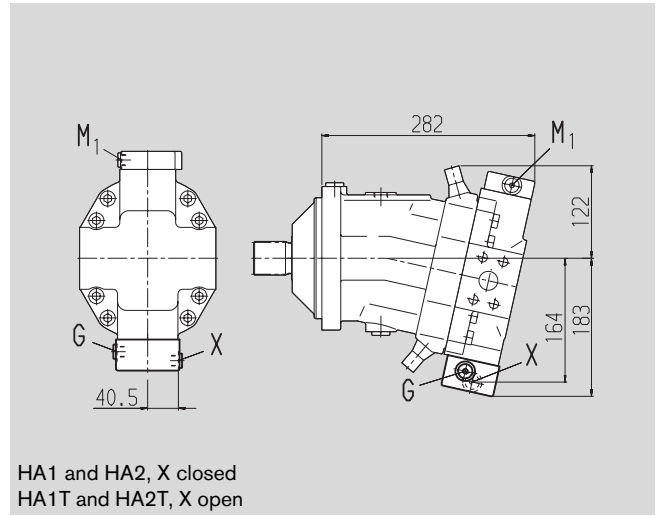

HA1 and HA2, X closed
HA1T and HA2T, X open

Automatic control, high-pressure dependent and electric override HA1U1, HA2U2

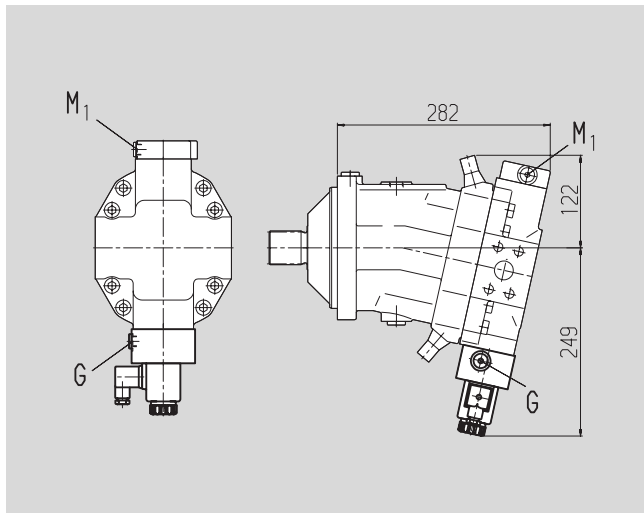

Automatic control, high-pressure dependent, electric override and elec. travel direction valve HA1R1, HA2R2

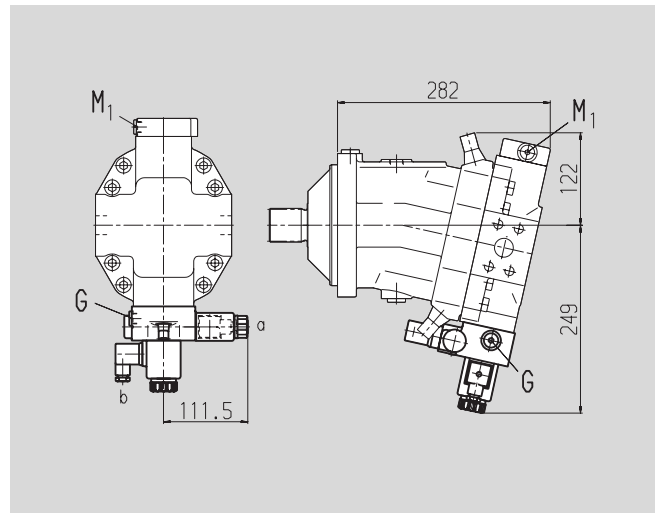

Hydraulic control, speed dependent and hydraulic travel direction valve DA1, DA4

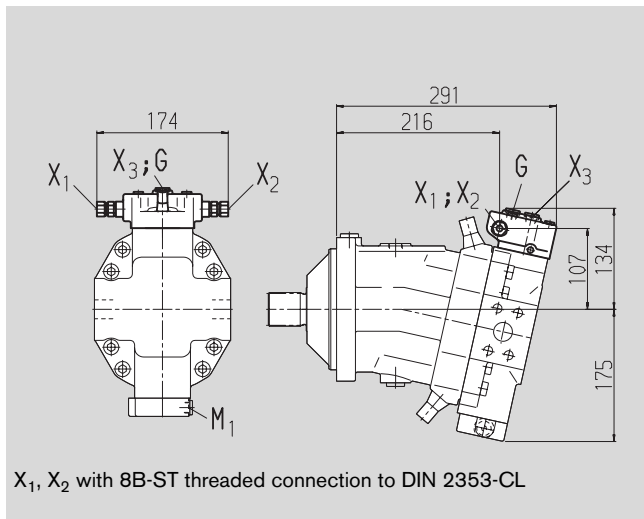

X1, X2 with 8B-ST threaded connection to DIN 2353-CL

Hydraulic control, speed dependent, elec. travel direction valve and elec. V_{g max} switch DA2, DA3, DA5, DA6

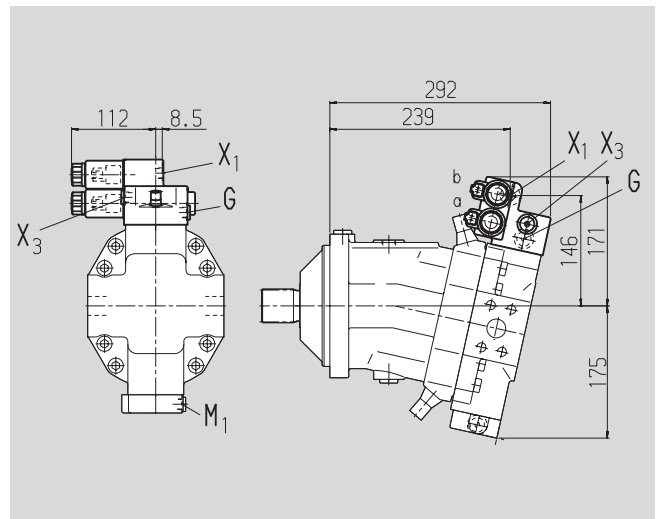

Unit Dimensions, Size 140

Before finalizing your design, please request approved installation drawing.

Hydraulic control, pilot pressure dependent HD1, HD2
 Hydraulic two-point control HZ1
 Service line ports A/B lateral, opposite (02)

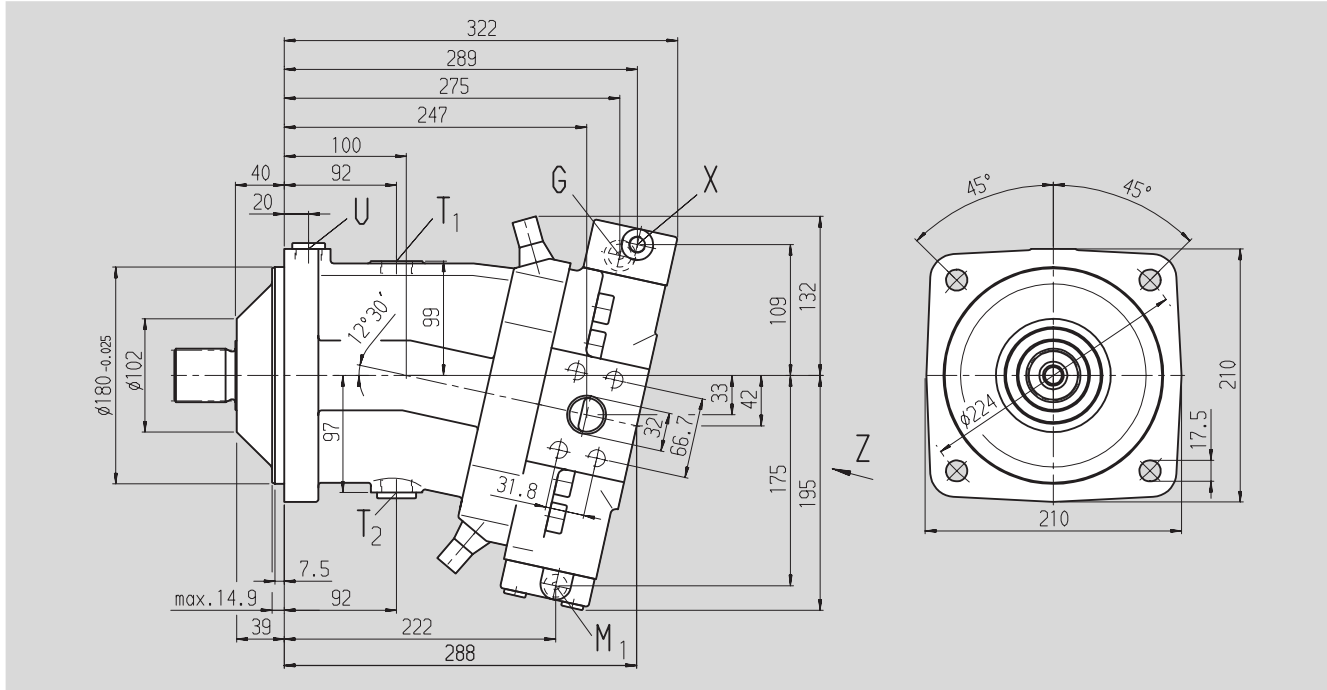

Shaft ends

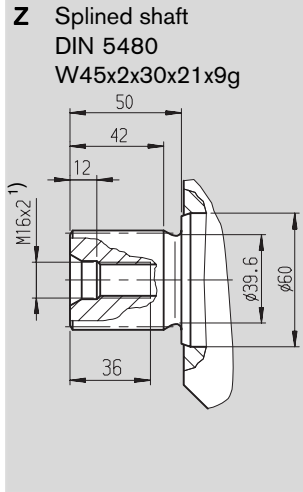
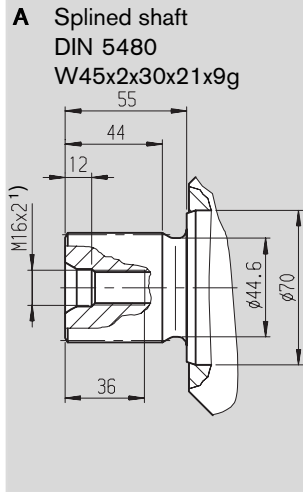

1) DIN 332 center hole

View Z
 Service line ports A/B
 lateral, opposite (02)

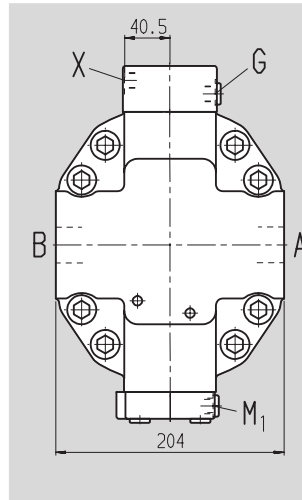

Service line ports A/B
 at rear (01)

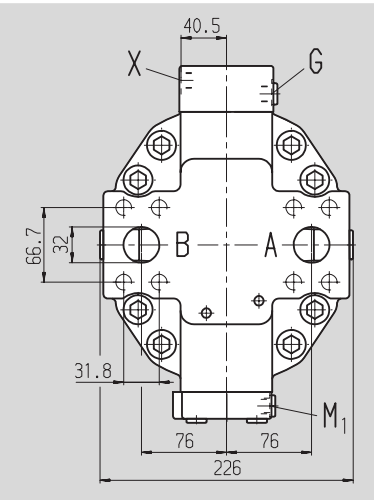

Ports

A, B	Service line port (high pressure series) Threaded fitting A/B	SAE J518, DIN 13	1 in M14x2; 19 deep	see safety instructions
T ₁	Leakage-fuel port	DIN 3852	M26x1.5; 16 deep	230 Nm
T ₂	Leakage fluid/oil drain ²⁾	DIN 3852	M26x1.5; 16 deep	230 Nm
X, X ₁ , X ₃	Pilot pressure port	DIN 3852	M14x1.5; 12 deep	80 Nm
G	Port for synchronous control of several units and for remote charge pressure ²⁾	DIN 3852	M14x1.5; 12 deep	80 Nm
G ₂	Port for 2nd pressure setting ²⁾	DIN 3852	M14x1.5; 12 deep	80 Nm
U	Flow port ²⁾	DIN 3852	M22x1.5; 14 deep	210 Nm
M ₁	Measuring port for charge pressure ²⁾	DIN 3852	M14x1.5; 12 deep	80 Nm

Tightening torque, max

²⁾ closed

Unit Dimensions, Size 140

Before finalizing your design, please request approved installation drawing.

Hydraulic control, pilot pressure dependent, with pressure control HD.D

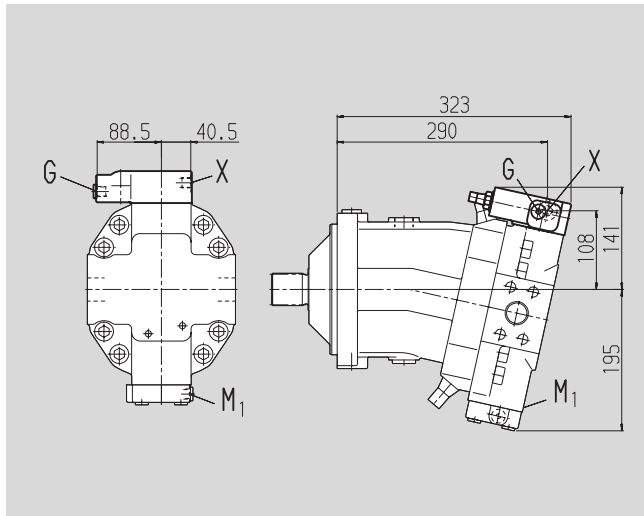

Hydraulic control, pilot pressure dependent, with pressure control, direct, with 2nd pressure setting HD.E

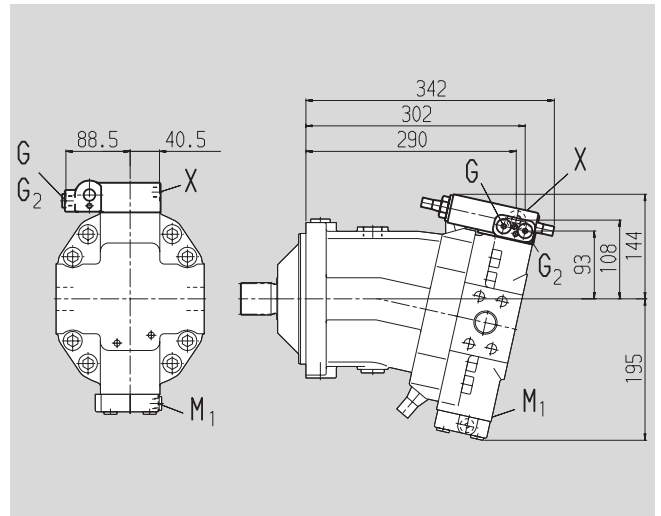

Electrical control with proportional solenoid EP1, EP2

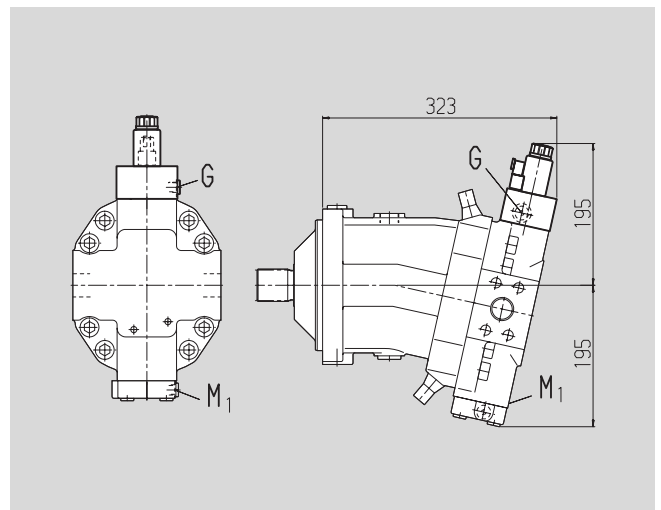

Electrical control (proportional solenoid) with pressure control, direct EP.D

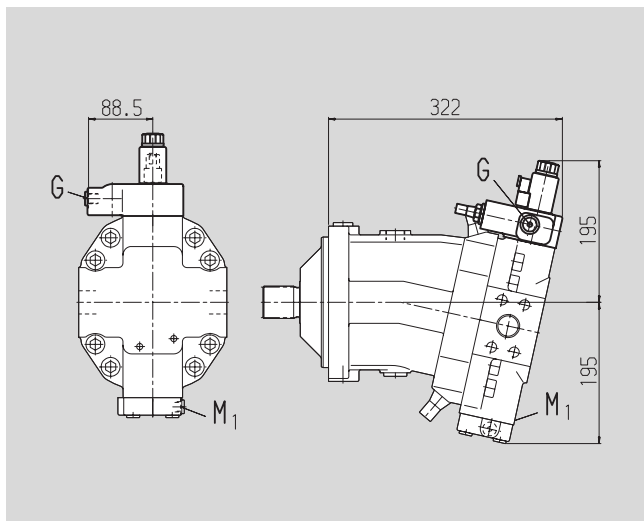

Electrical control (proportional solenoid) with pressure control, remote EP.E

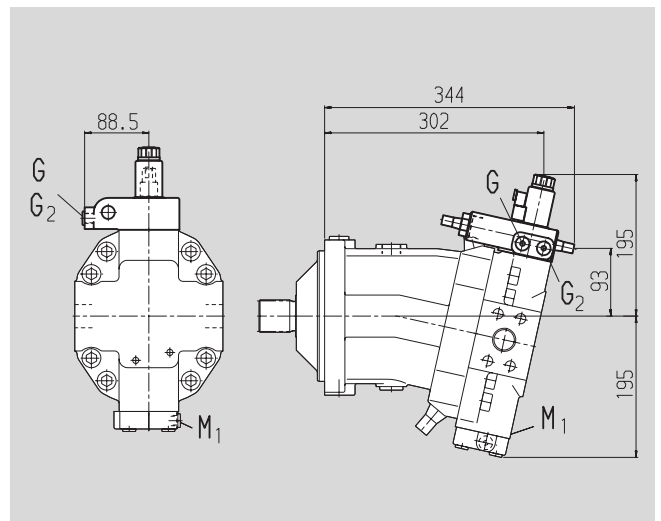

Unit Dimensions, Size 140

Before finalizing your design, please request approved installation drawing.

Electrical two-point control with solenoid E21, E22

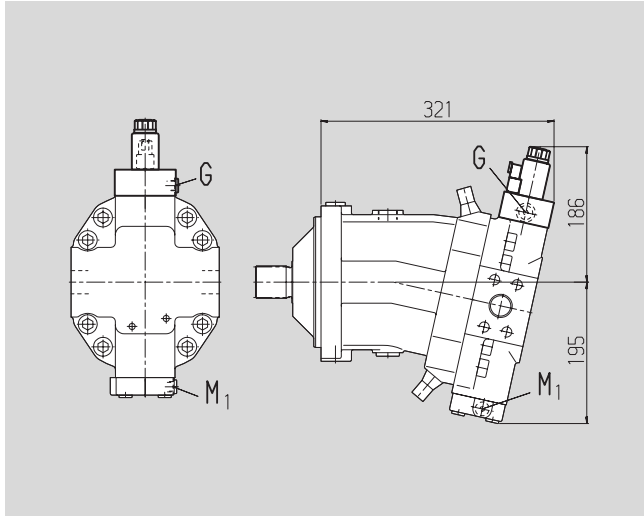

Automatic control, high-pressure dependent and electric override HA1U1, HA2U2

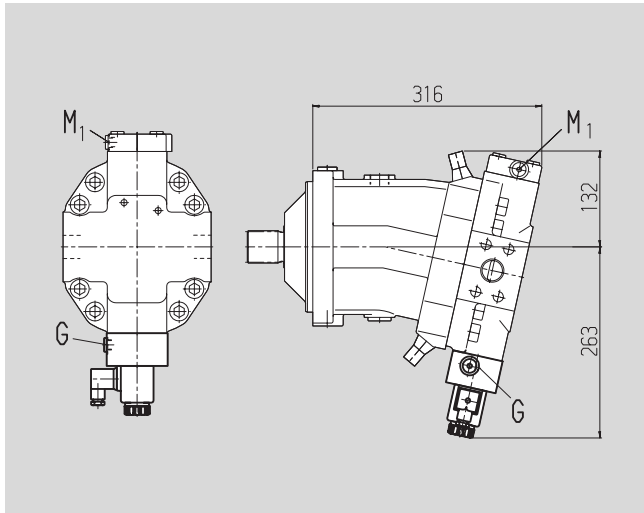

Hydraulic control, speed dependent and hydraulic travel direction valve DA1, DA4

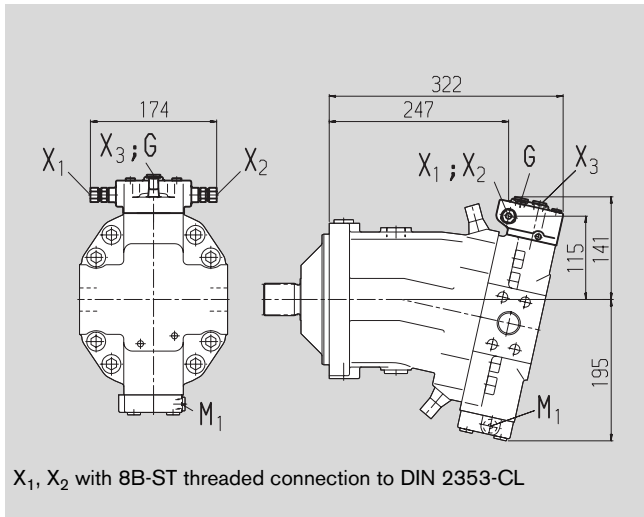

Automatic control, high-pressure dependent HA1, HA2, and hydraulic override HA1T, HA2T

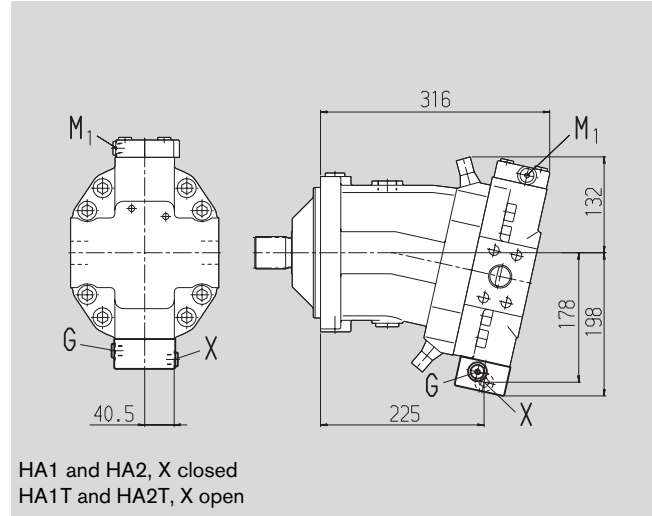

Automatic control, high-pressure dependent, electric override and elec. travel direction valve HA1R1, HA2R2

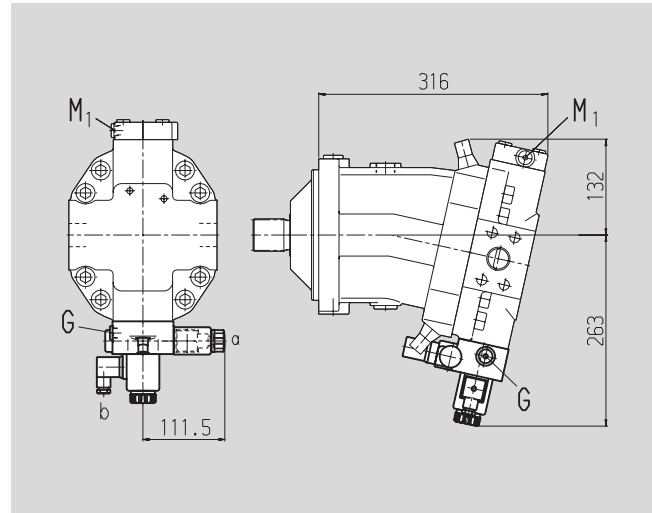

Hydraulic control, speed dependent, elec. travel direction valve and elec. $V_{g \max}$ switch DA2, DA3, DA5, DA6

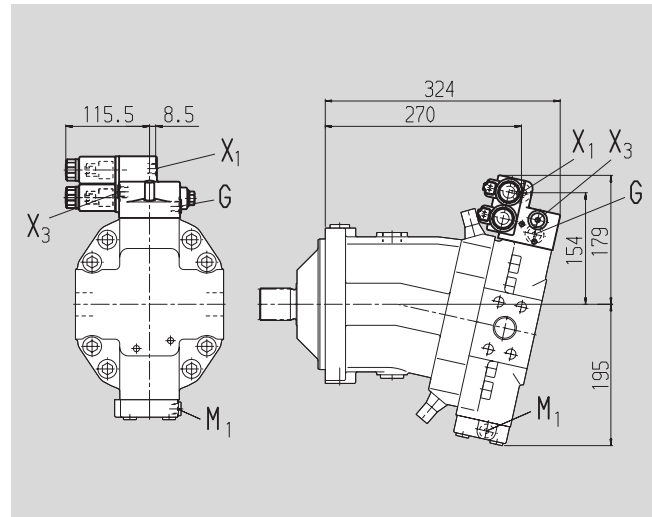

Unit Dimensions, Size 160

Before finalizing your design, please request approved installation drawing.

Hydraulic control, pilot pressure dependent HD1, HD2

Hydraulic two-point control HZ1

Service line ports A/B lateral, opposite (02)

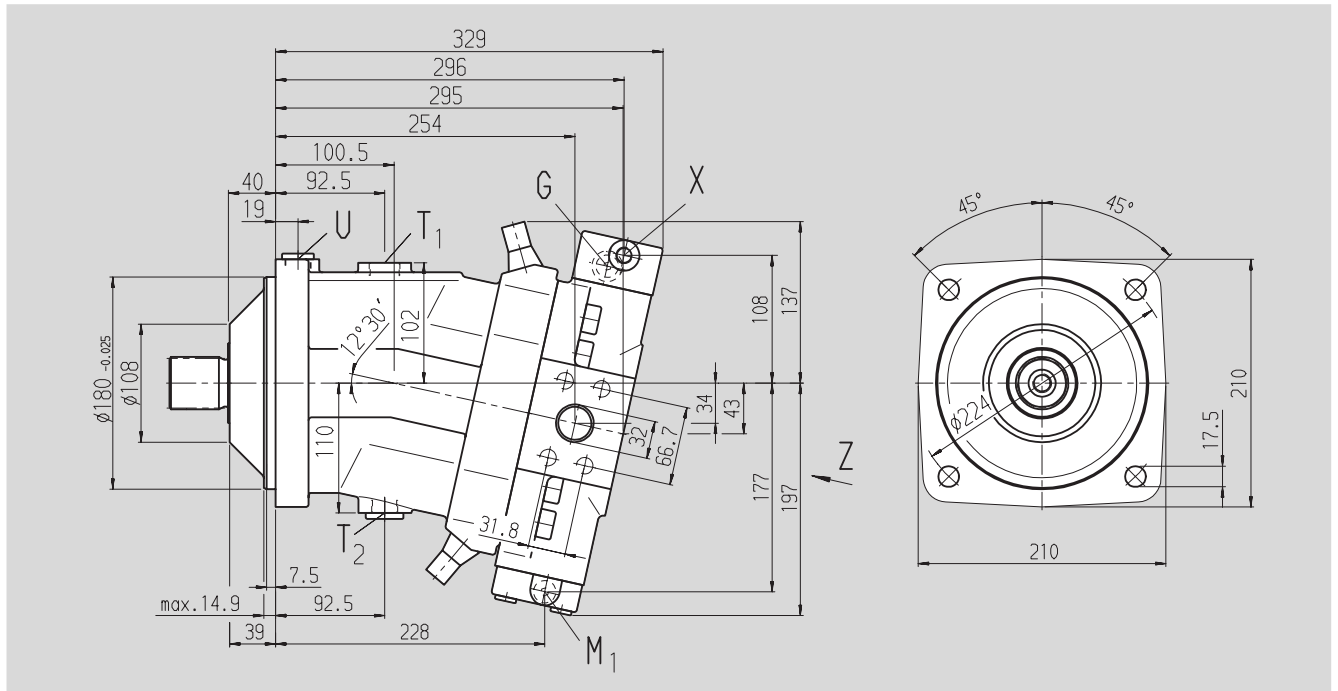

View Z

Shaft ends

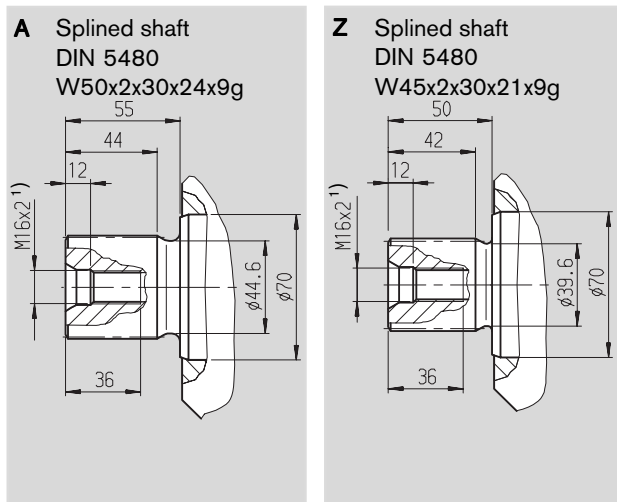

1) DIN 332 center hole

Service line ports A/B lateral, opposite (02)

Service line ports A/B at rear (01)

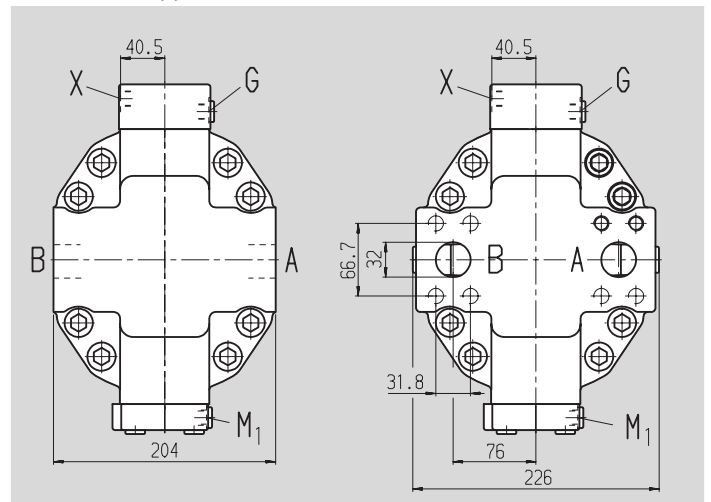

Ports

A, B	Service line port (high pressure series) Threaded fitting A/B
T ₁	Leakage-fuel port
T ₂	Leakage fluid/oil drain ²⁾
X, X ₁ , X ₃	Pilot pressure port
G	Port for synchronous control of several units and for remote charge pressure ²⁾
G ₂	Port for 2nd pressure setting ²⁾
U	Flow port ²⁾
M ₁	Measuring port for charge pressure ²⁾

SAE J518,
DIN 13
DIN 3852
DIN 3852
DIN 3852
DIN 3852
DIN 3852
DIN 3852
DIN 3852

1 1/4 in
M14x2; 19 deep
M26x1.5; 16 deep
M26x1.5; 16 deep
M14x1.5; 12 deep
M14x1.5; 12 deep
M14x1.5; 12 deep
M14x1.5; 12 deep
M14x1.5; 12 deep
M14x1.5; 12 deep

Tightening torque, max

see safety instructions
230 Nm
230 Nm
80 Nm
80 Nm
80 Nm
230 Nm
80 Nm

²⁾ closed

Unit Dimensions, Size 160

Before finalizing your design, please request approved installation drawing.

Hydraulic control, pilot pressure dependent, with pressure control, direct HD.D

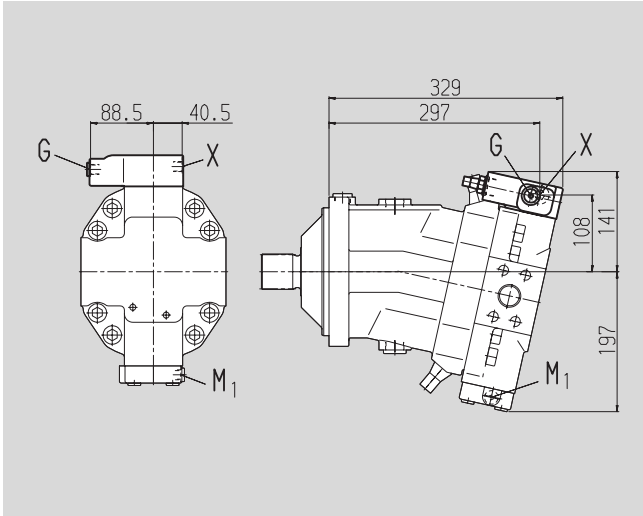

Hydraulic control, pilot pressure dependent, with pressure control, direct and 2nd pressure setting HD.E

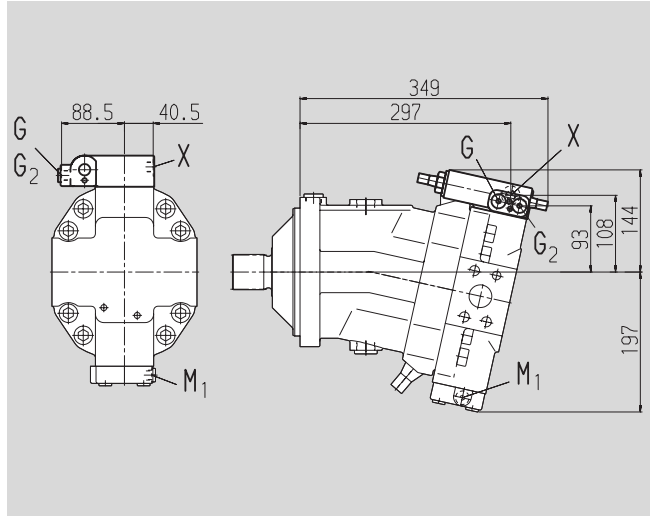

Electrical control with proportional solenoid EP1, EP2

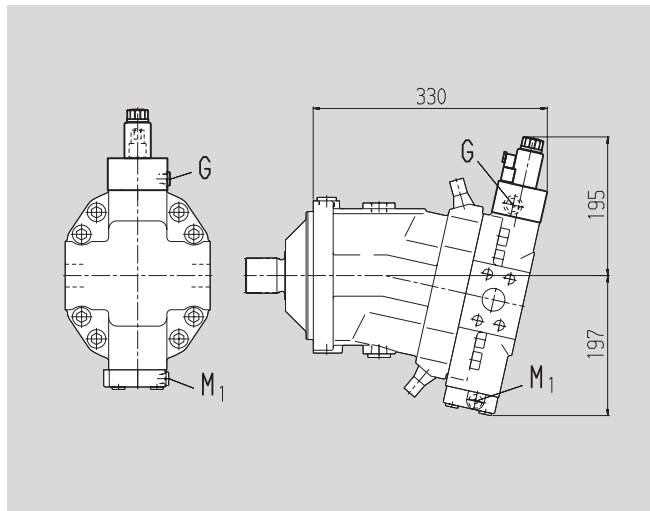

Electrical control (proportional solenoid) with pressure control, direct EP.D

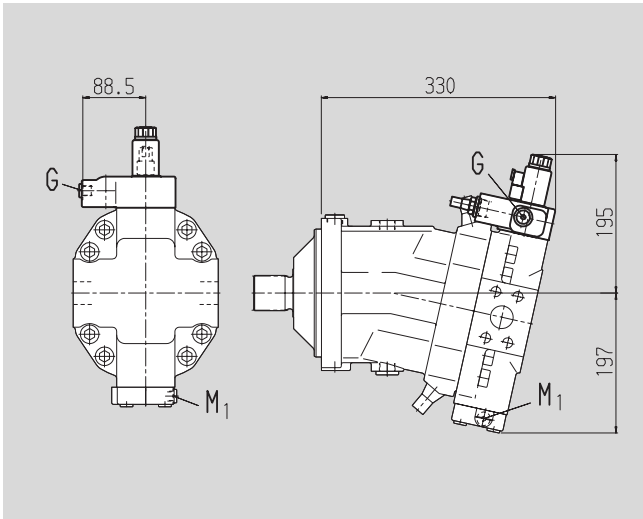

Electrical control (proportional solenoid) with pressure control, direct and 2nd pressure setting EP.E

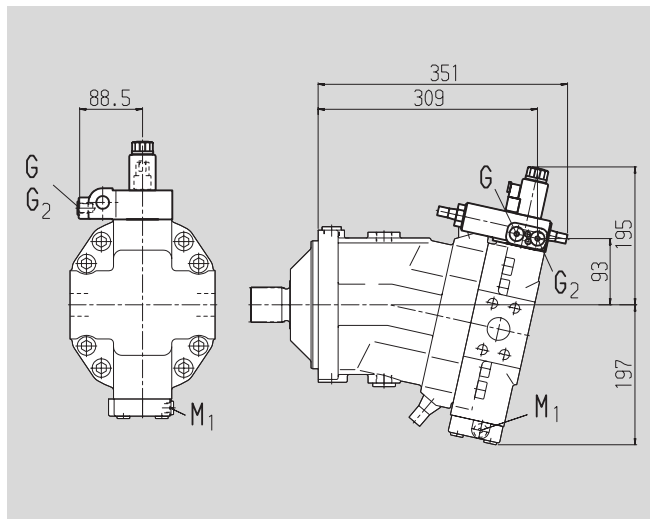

Unit Dimensions, Size 160

Before finalizing your design, please request approved installation drawing.

Electrical two-point control with solenoid EZ1, EZ2

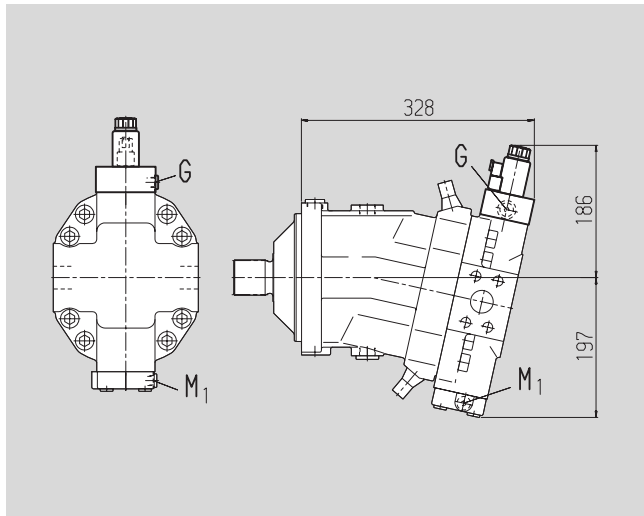

Automatic control, high-pressure dependent and electric override HA1U1, HA2U2

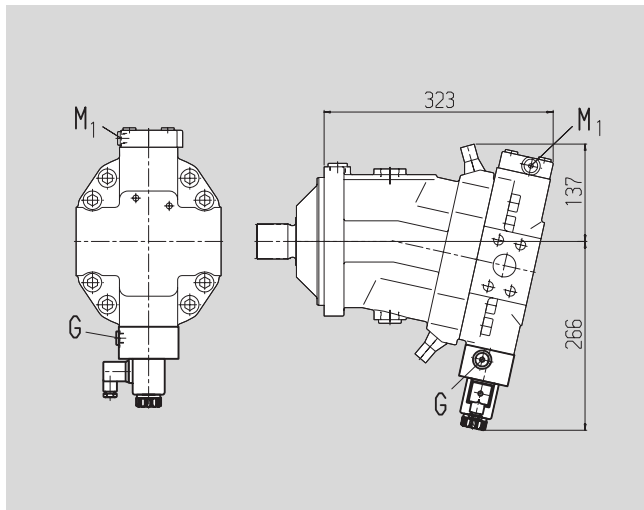

Hydraulic control, speed dependent and hydraulic travel direction valve DA1, DA4

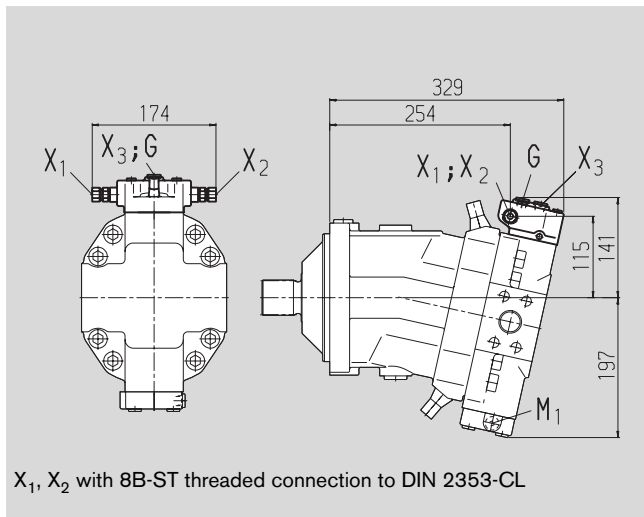

X₁, X₂ with 8B-ST threaded connection to DIN 2353-CL

Automatic control, high-pressure dependent HA1, HA2, and hydraulic override HA1T, HA2T

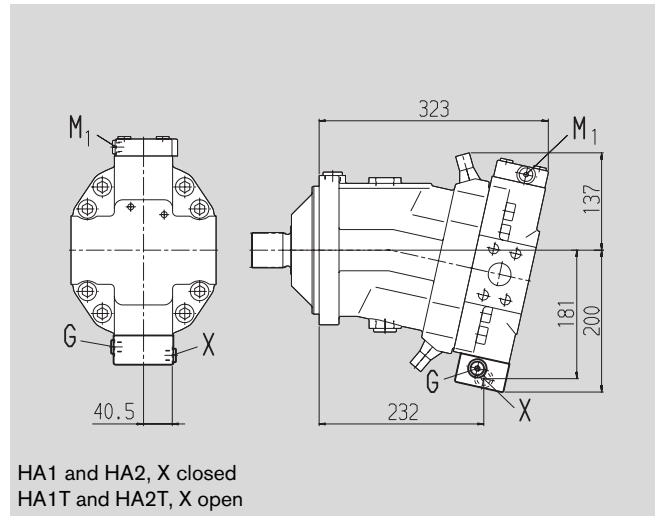

HA1 and HA2, X closed
HA1T and HA2T, X open

Automatic control, high-pressure dependent, electric override and elec. travel direction valve HA1R1, HA2R2

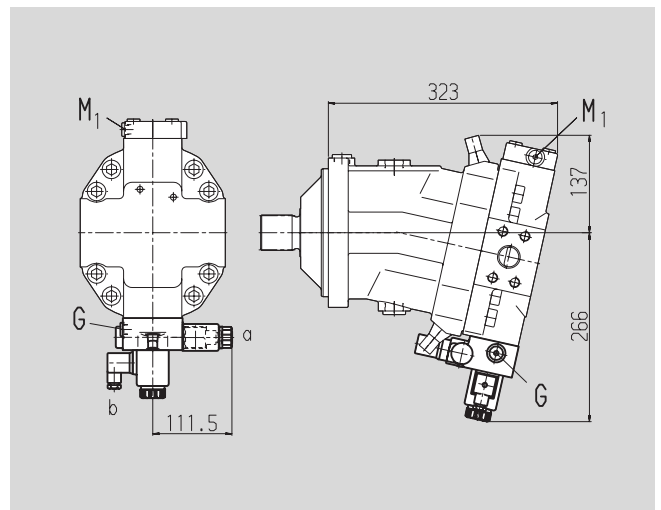

Hydraulic control, speed dependent, elec. travel direction valve and elec. V_{g max} switch DA2, DA3, DA5, DA6

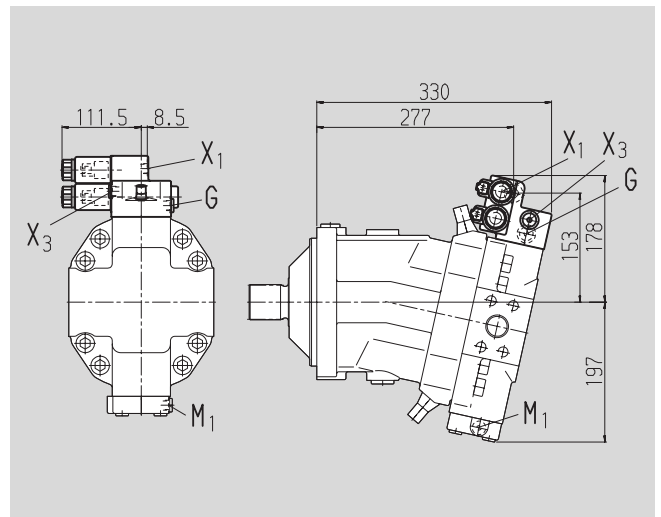

Unit Dimensions, Size 200

Before finalizing your design, please request approved installation drawing.

Hydraulic control, pilot pressure dependent HD1, HD2
 Hydraulic two-point control HZ1
 Service line ports A/B lateral, opposite (02)

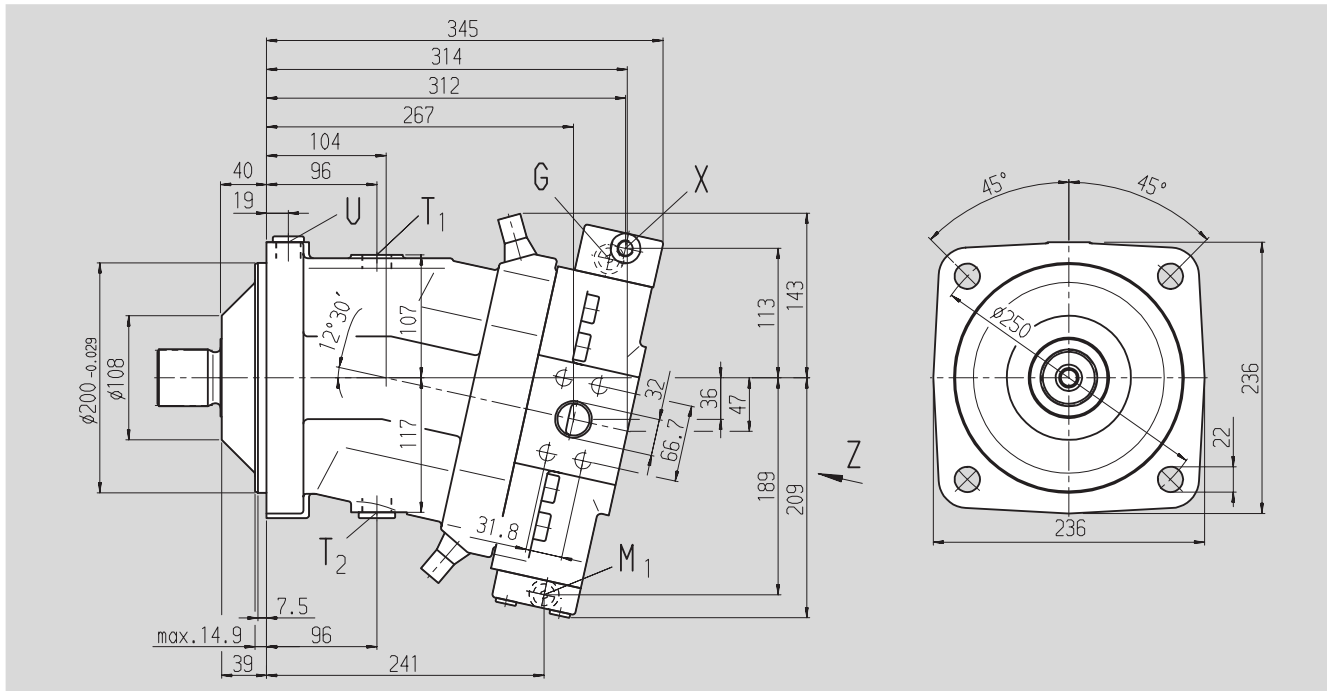

Shaft ends

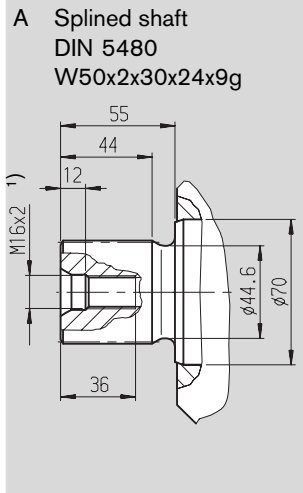

1) DIN 332 center hole

View Z
 Service line ports A/B lateral, opposite (02)

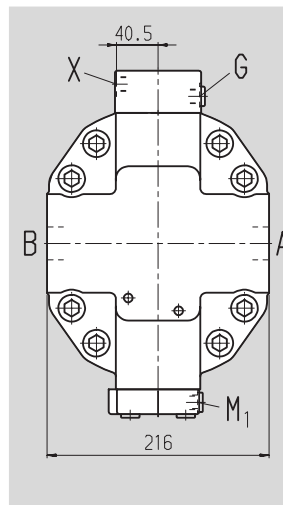

Service line ports A/B at rear (01)

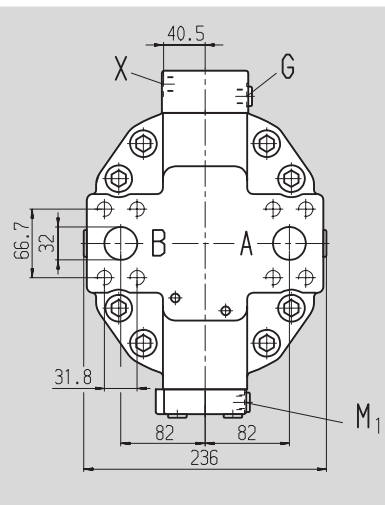

Ports

- A, B Service line port (high pressure series)
Threaded fitting A/B
- T₁ Leakage-fuel port
- T₂ Leakage fluid/oil drain ²⁾
- X, X₁, X₃ Pilot pressure port
- G Port for synchronous control of several units and for remote charge pressure ²⁾
- G₂ Port for 2nd pressure setting ²⁾
- U Flow port ²⁾
- M₁ Measuring port for charge pressure ²⁾

- SAE J518, 11/4 in
- DIN 13 M14x2; 19 deep
- DIN 3852 M26x1.5; 16 deep
- DIN 3852 M26x1.5; 16 deep
- DIN 3852 M14x1.5; 12 deep
- DIN 3852 M14x1.5; 12 deep
- DIN 3852 M14x1.5; 12 deep
- DIN 3852 M14x1.5; 12 deep
- DIN 3852 M22x1.5; 14 deep
- DIN 3852 M14x1.5; 12 deep

Tightening torque, max

- see safety instructions
- 230 Nm
- 230 Nm
- 80 Nm
- 80 Nm
- 80 Nm
- 80 Nm
- 210 Nm
- 80 Nm

²⁾ closed

Unit Dimensions, Size 200

Before finalizing your design, please request approved installation drawing.

Hydraulic control, pilot pressure dependent, with pressure control, direct HD.D

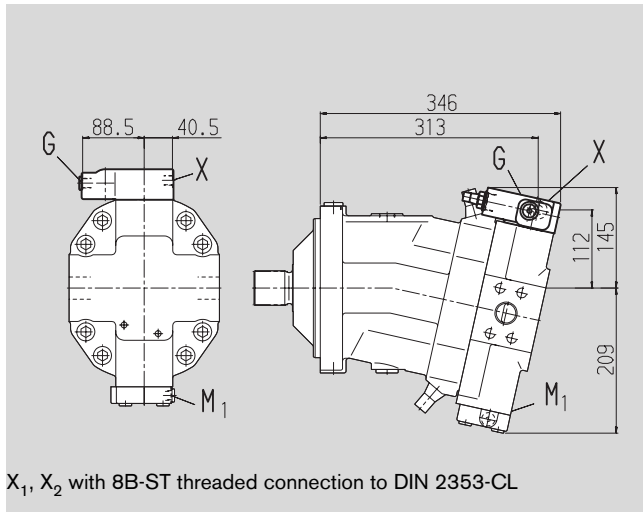

X₁, X₂ with 8B-ST threaded connection to DIN 2353-CL

Hydraulic control, pilot pressure dependent, with pressure control, direct and 2nd pressure setting HD.E

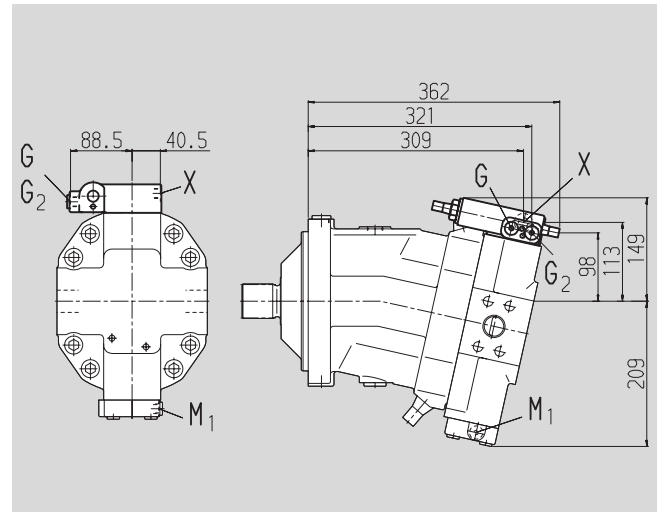

Electrical control with proportional solenoid EP1, EP2

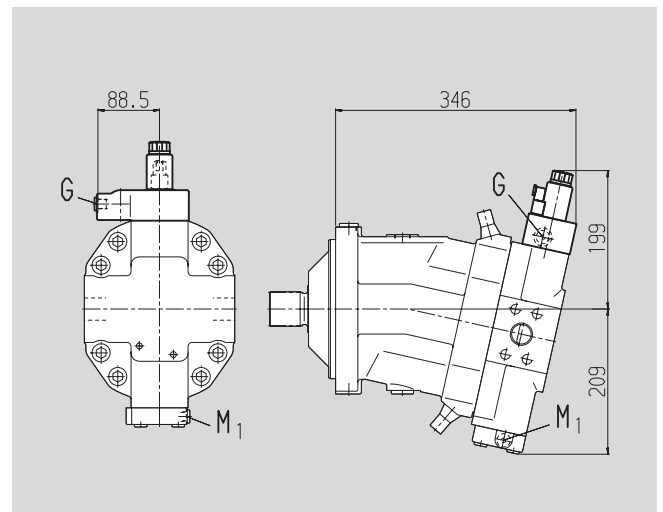

Electrical control (proportional solenoid) with pressure control, direct EP.D

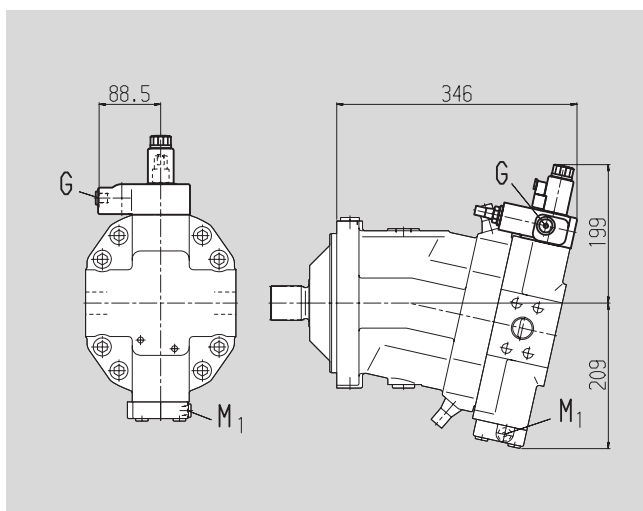

Electrical control (proportional solenoid) with pressure control, direct and 2nd pressure setting EP.E

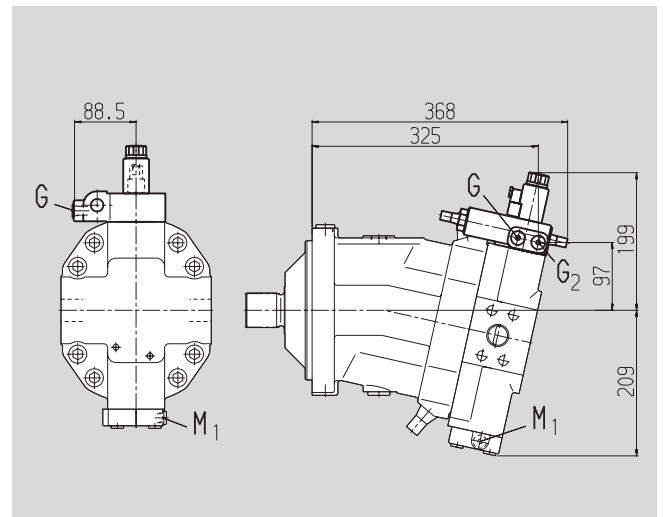

Unit Dimensions, Size 200

Before finalizing your design, please request approved installation drawing.

Electrical two-point control with solenoid EZ1, EZ2

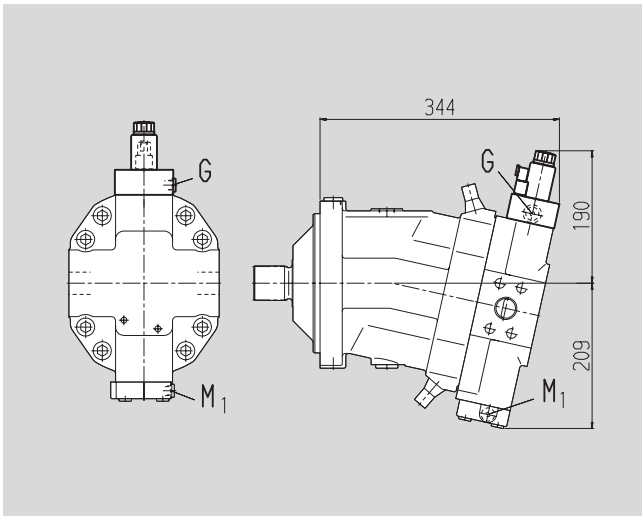

Automatic control, high-pressure dependent and electric override HA1U1, HA2U2

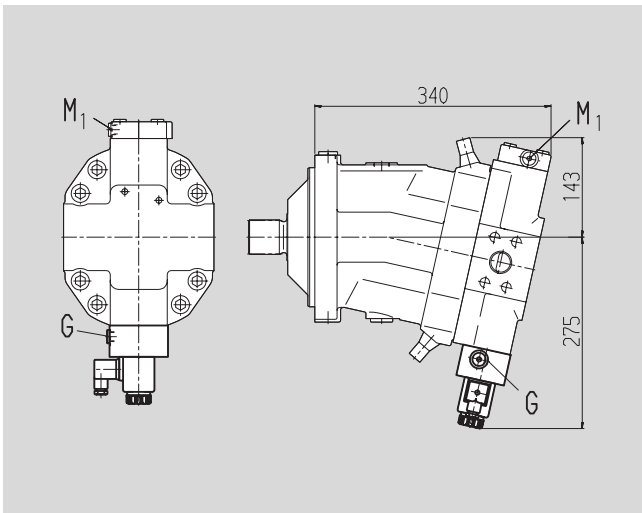

Hydraulic control, speed dependent and hydraulic travel direction valve DA1, DA4

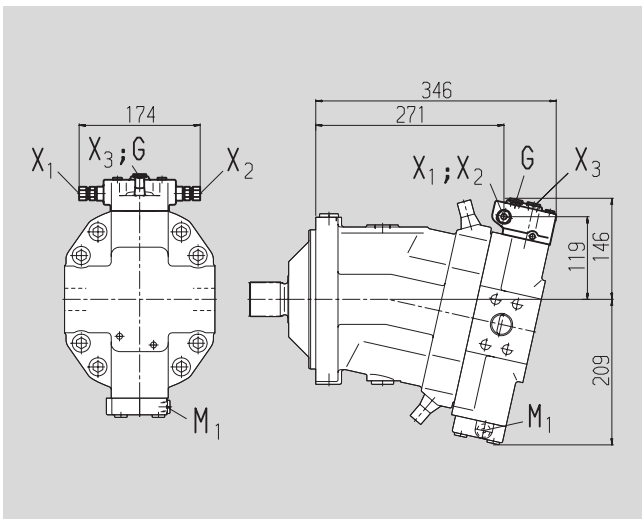

Automatic control, high-pressure dependent HA1, HA2, and hydraulic override HA1T, HA2T

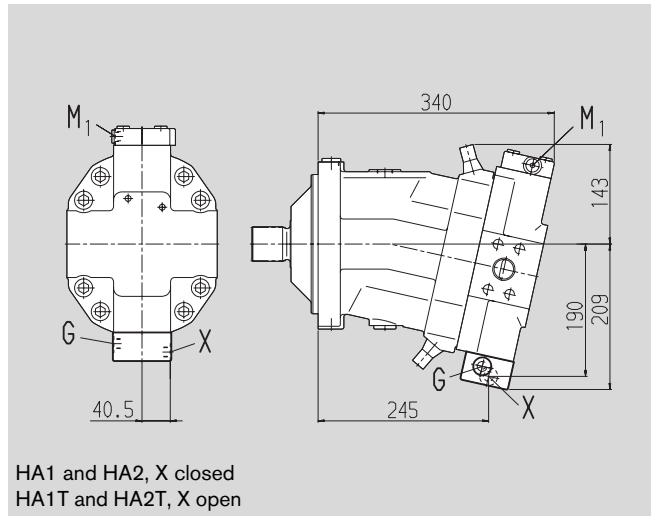

HA1 and HA2, X closed
HA1T and HA2T, X open

Automatic control, high-pressure dependent, electric override and elec. travel direction valve HA1R1, HA2R2

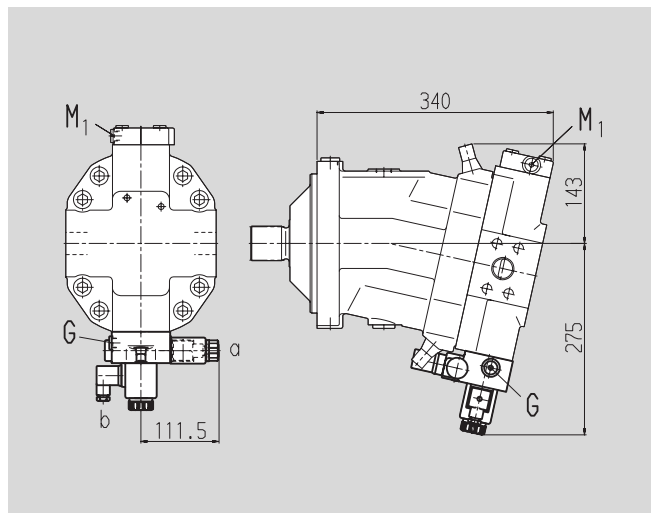

Hydraulic control, speed dependent, elec. travel direction valve and elec. $V_{g \max}$ switch DA2, DA3, DA5, DA6

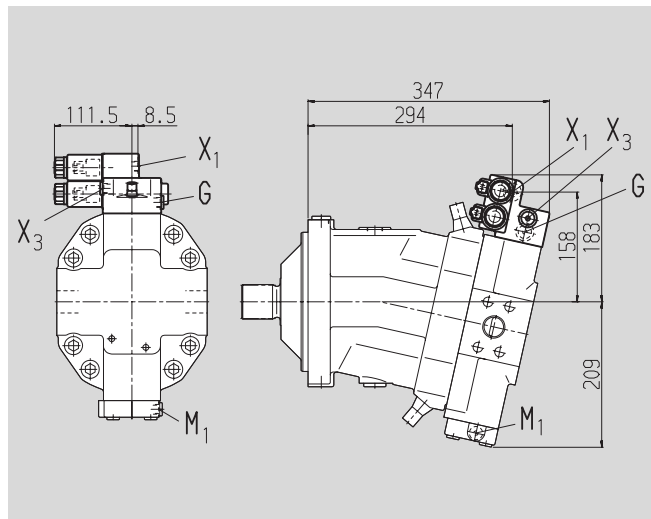

Unit Dimensions, Size 250

Before finalizing your design, please request approved installation drawing.

Hydraulic control, control-pressure dependent HD1, HD2, HD3

Hydraulic two-point control HZ

Service line ports A/B lateral, opposite (02)

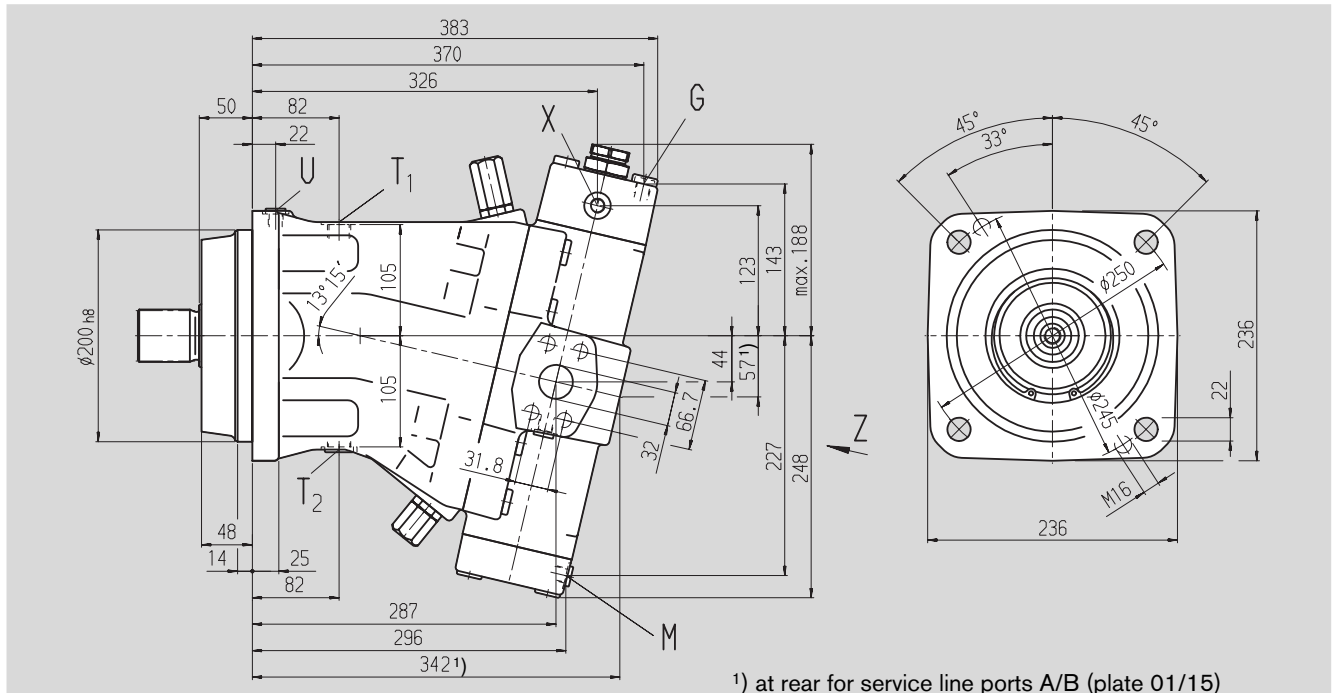

View Z

Service line ports A/B lateral, opposite (02)

Service line ports A/B at rear (01)

Service line ports A/B/A1/B1 lateral, opposite + at rear (15)

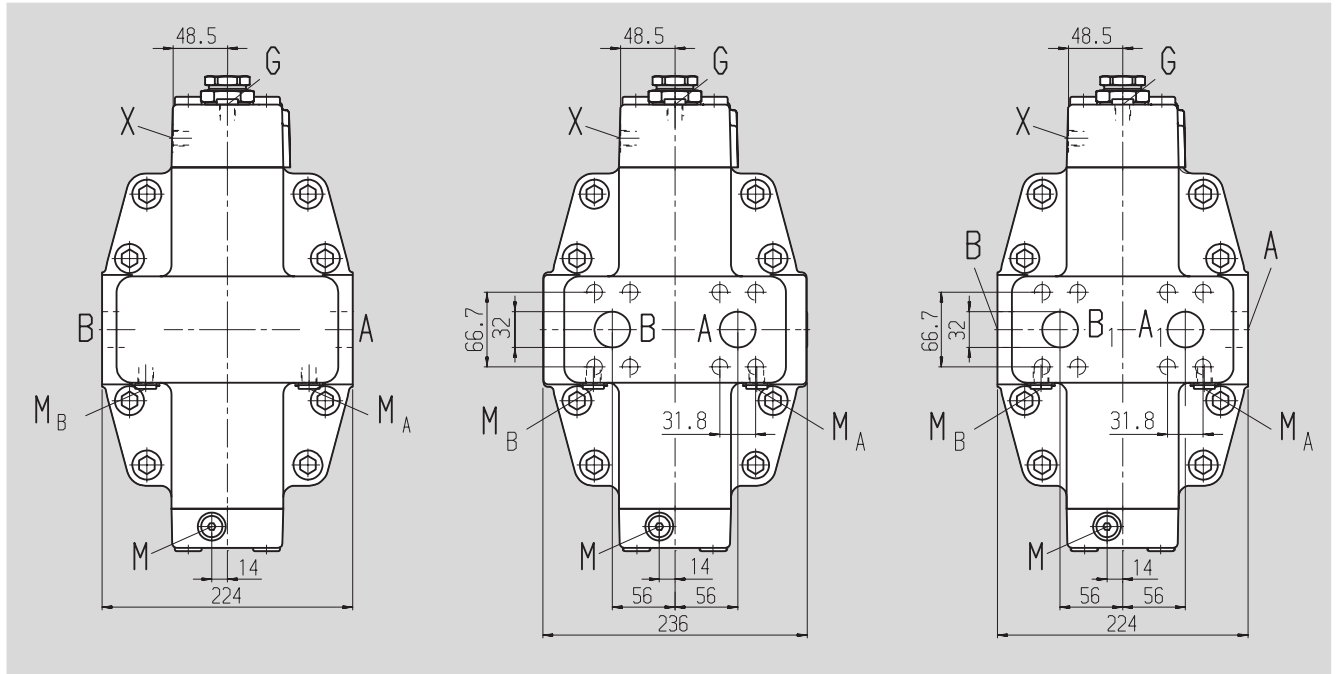

Unit Dimensions, Size 250

Before finalizing your design, please request approved installation drawing.

Shaft ends

Z Splined shaft
DIN 5480
W50x2x30x24x9g

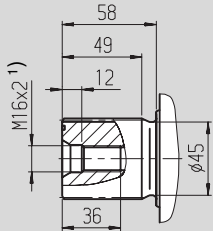

P Cyl. shaft,
with adjusting spring
DIN 6885 AS14x9x80

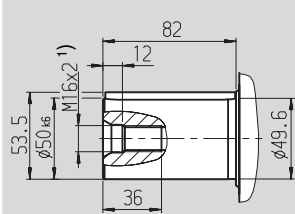

1) DIN 332 center hole

Ports

Port	Description	Standard	Size	Tightening torque, max
A, B	Service line port (high pressure series)	SAE J518,	1 1/4 in	
A ₁ , B ₁	Additional service line ports for plate 15	SAE J518,	1 1/4 in	
	Threaded fitting A/B	DIN 13	M14x2; 19 deep	see safety instructions
T ₁	Leakage-fuel port	DIN 3852	M22x1.5; 14 deep	210 Nm
T ₂	Leakage fluid/oil drain ²⁾	DIN 3852	M22x1.5; 14 deep	210 Nm
X	Pilot pressure port	DIN 3852	M14x1.5; 12 deep	80 Nm
X ₃	Port for remote control valve	DIN 3852	M14x1.5; 12 deep	80 Nm
P	Connection for charge oil supply	DIN 3852	M14x1.5; 12 deep	80 Nm
G	Port for synchronous control of several units and for remote charge pressure ²⁾	DIN 3852	M14x1.5; 12 deep	80 Nm
G ₂	Port for 2nd pressure setting ²⁾	DIN 3852	M14x1.5; 12 deep	80 Nm
U	Flow port ²⁾	DIN 3852	M14x1.5; 12 deep	80 Nm
M	Measuring port for charge pressure ²⁾	DIN 3852	M14x1.5; 12 deep	80 Nm
M _A , M _B	Measuring port for operating pressure ²⁾	DIN 3852	M14x1.5; 12 deep	80 Nm
M _{St}	Measuring port for pilot pressure ²⁾	DIN 3852	M14x1.5; 12 deep	80 Nm

²⁾ closed

Tightening torque, max

Unit Dimensions, Size 250

Before finalizing your design, please request approved installation drawing.

Hydraulic control, pilot pressure dependent, with pressure control, direct HD.D, remote control HD.G

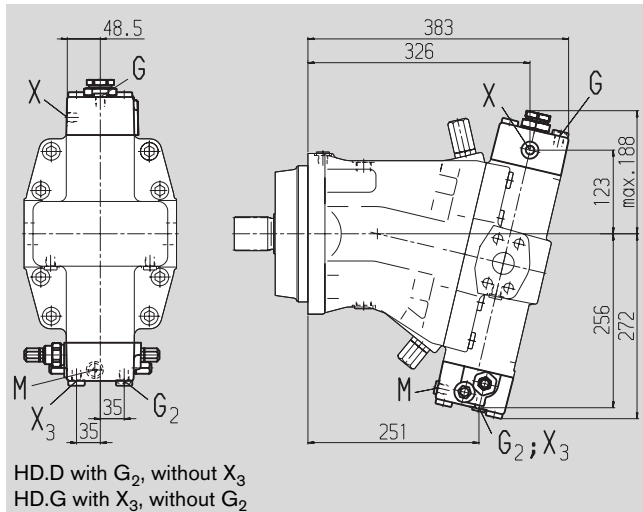

Electrical control with proportioning valve EP1, EP2

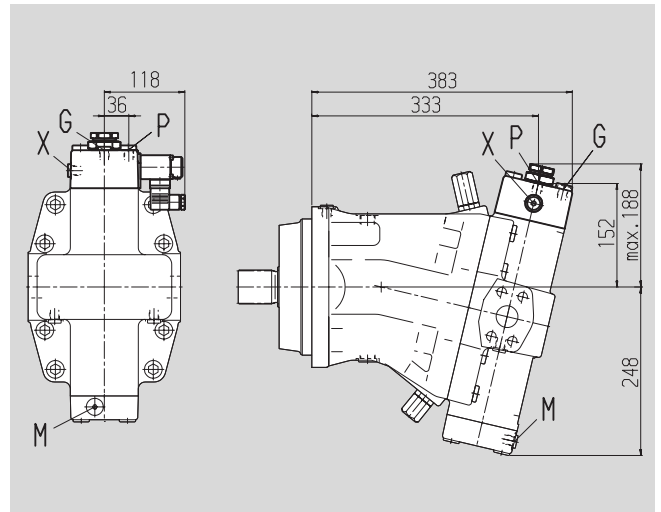

Electrical control (proportioning valve) with pressure control, direct EP.D. remote EP.G

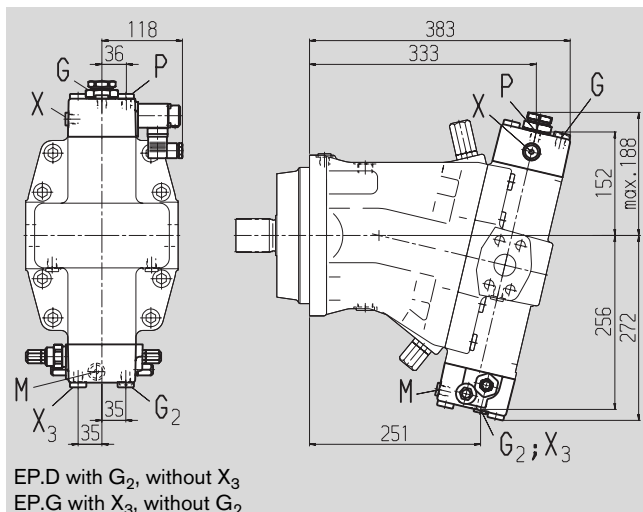

Electrical two-point control with solenoid EZ1, EZ2

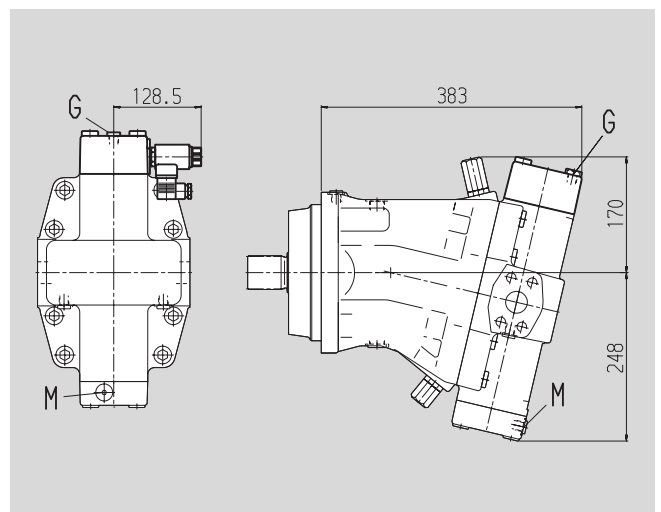

Automatic control, high-pressure dependent HA1, HA2, with hydraulic override HA1T, HA2T

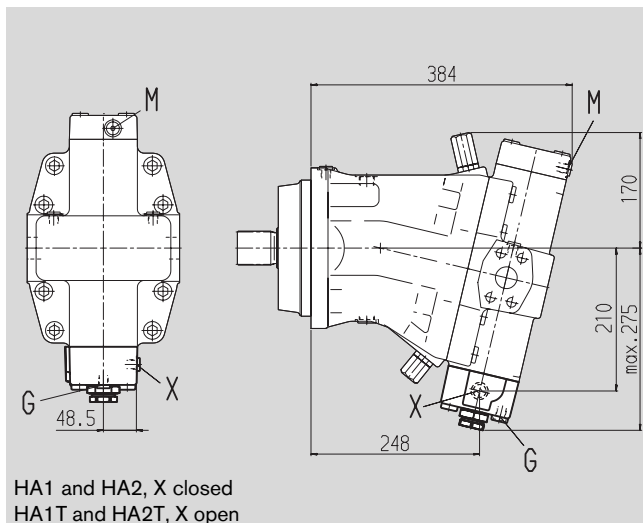

Hydraulic control, speed dependent DA

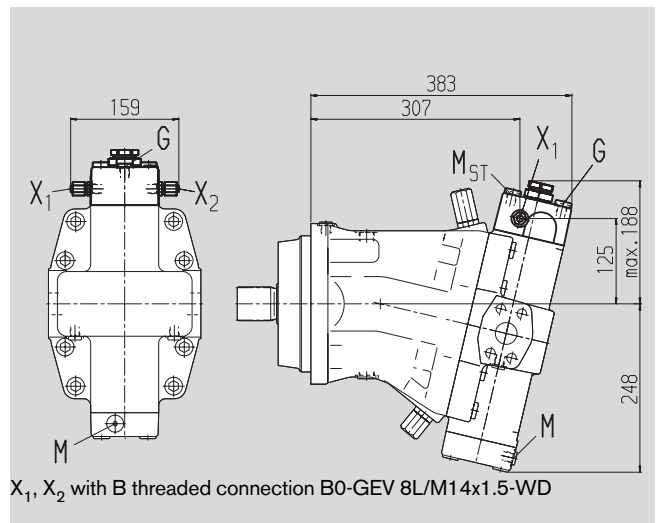

Unit Dimensions, Size 355

Before finalizing your design, please request approved installation drawing.

Shaft ends

Z Splined shaft
DIN 5480
W60x2x30x28x9g

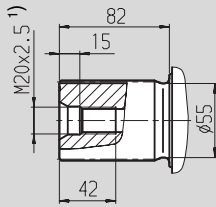

P Cyl. shaft, with
adjusting spring
DIN 6885 AS18x11x100

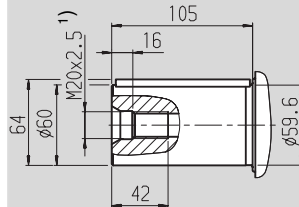

1) DIN 332 center hole

Ports

Port	Description	SAE	SAE Size	Depth	Tightening torque, max
A, B	Service line port (high pressure series)	SAE J518,	1 1/2 in		
A ₁ , B ₁	Additional service line ports for plate 15	SAE J518,	1 1/4 in		
	Threaded fitting A/B	DIN 13	M16x2;	24 deep	see safety instructions
T ₁	Leakage-fuel port	DIN 3852	M33x2;	18 deep	540 Nm
T ₂	Leakage fluid/oil drain ²⁾	DIN 3852	M33x2;	18 deep	540 Nm
X, X ₁ , X ₂	Pilot pressure port	DIN 3852	M14x1.5;	12 deep	80 Nm
X ₃	Port for remote control valve	DIN 3852	M14x1.5;	12 deep	80 Nm
P	Connection for charge oil supply	DIN 3852	M14x1.5;	12 deep	80 Nm
G	Port for synchronous control of several units and for remote charge pressure ²⁾	DIN 3852	M14x1.5;	12 deep	80 Nm
G ₂	Port for 2nd pressure setting ²⁾	DIN 3852	M14x1.5;	12 deep	80 Nm
U	Flow port ²⁾	DIN 3852	M14x1.5;	12 deep	80 Nm
M	Measuring port for charge pressure ²⁾	DIN 3852	M14x1.5;	12 deep	80 Nm
M _A , M _B	Measuring port for operating pressure ²⁾	DIN 3852	M14x1.5;	12 deep	80 Nm
M _{St}	Measuring port for pilot pressure ²⁾	DIN 3852	M14x1.5;	12 deep	80 Nm

²⁾ closed

Unit Dimensions, Size 355

Before finalizing your design, please request approved installation drawing.

Hydraulic control, pilot pressure dependent, with pressure control, direct HD.D, remote control HD.G

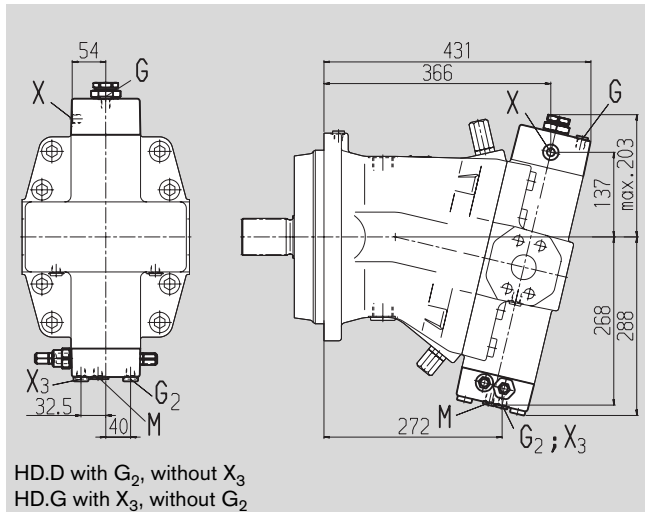

Electrical control with proportioning valve EP1, EP2

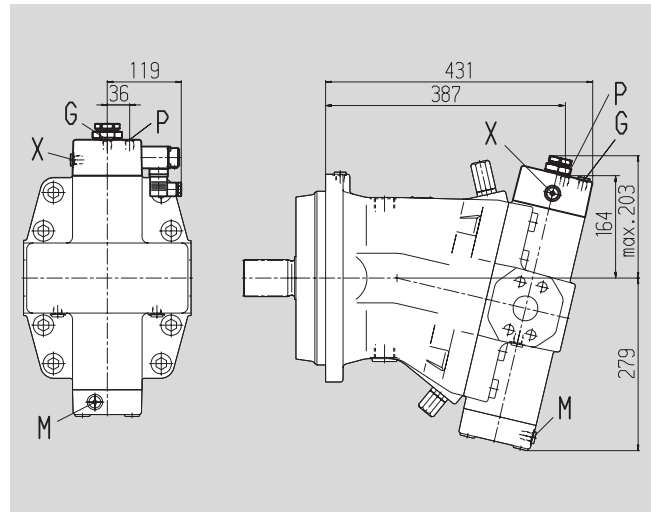

Electrical control (proportioning valve) with pressure control, direct EP.D, remote EP.G

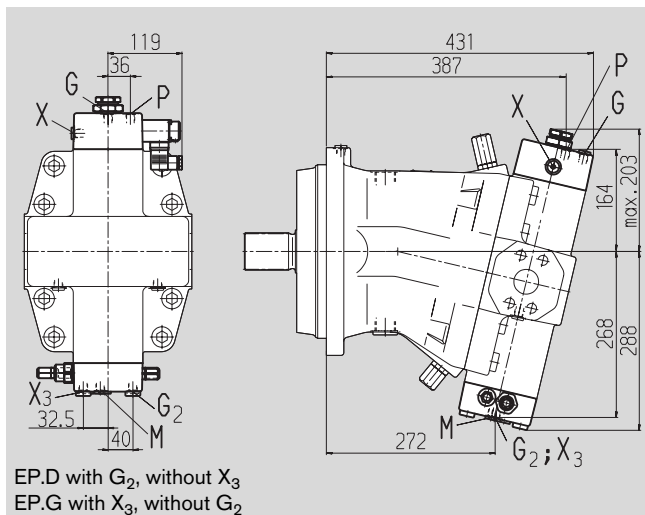

Electrical two-point control with solenoid EZ1, EZ2

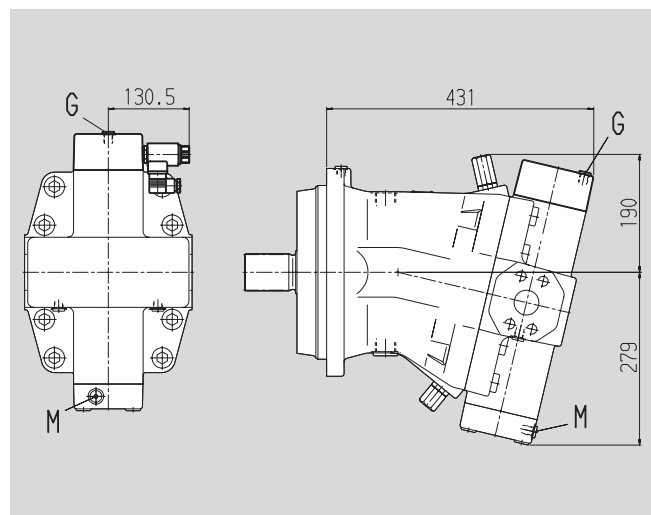

Automatic control, high-pressure dependent HA1, HA2, with hydraulic override HA1T, HA2T

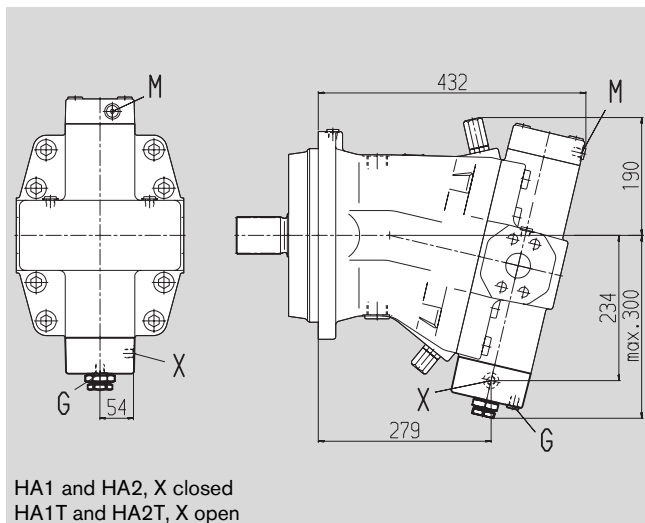

Hydraulic control, speed dependent DA

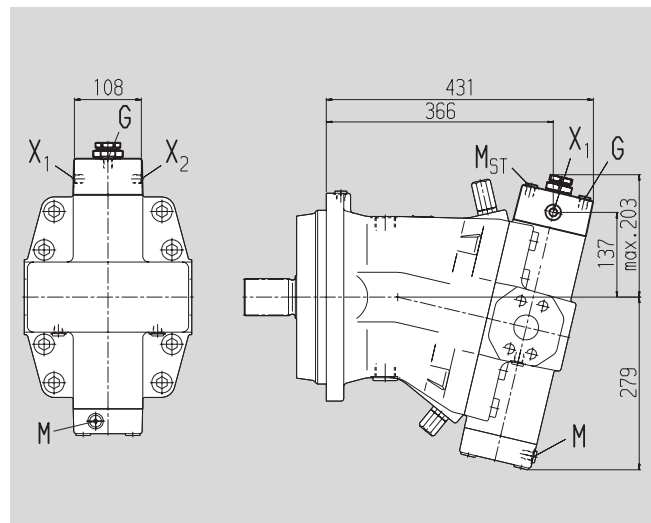

Unit Dimensions, Size 500

Before finalizing your design, please request approved installation drawing.

Hydraulic control, pilot pressure dependent HD1, HD2, HD3

Hydraulic two-point control HZ

Service line ports A/B lateral, opposite (02)

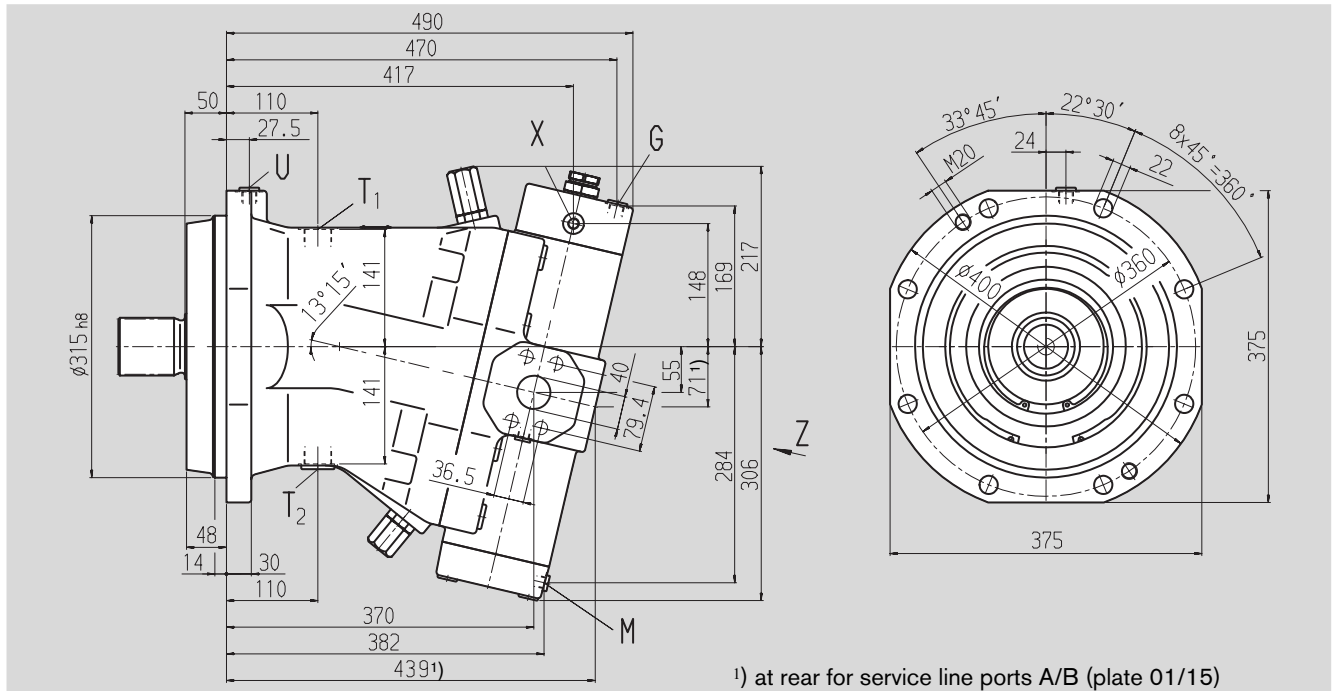

View Z

Service line ports A/B lateral, opposite (02)

Service line ports A/B at rear (01)

Service line ports A/B / A₁ / B₁ lateral, opposite + at rear (15)

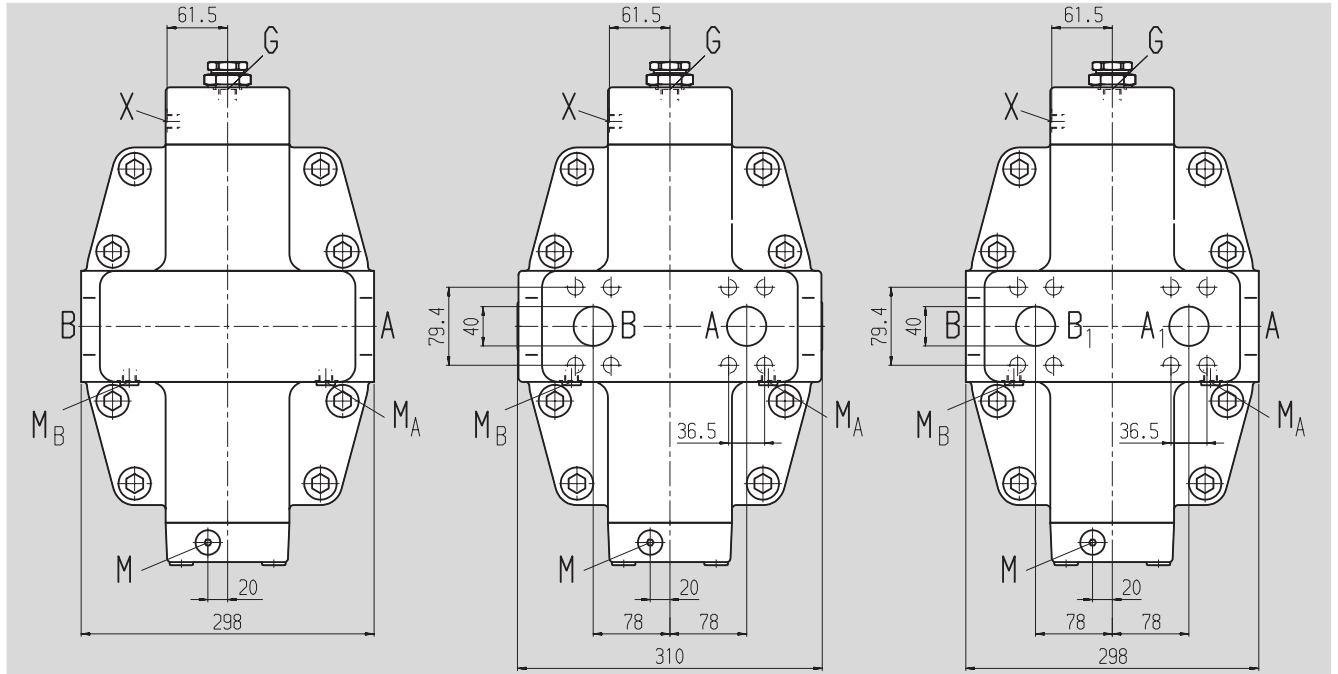

Unit Dimensions, Size 500

Before finalizing your design, please request approved installation drawing.

Shaft ends

Z Splined shaft
DIN 5480
W70x3x30x22x9g

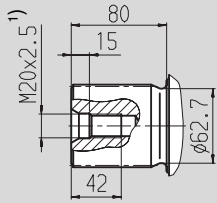

P Cyl. shaft,
with adjusting spring
DIN 6885
AS20x12x100

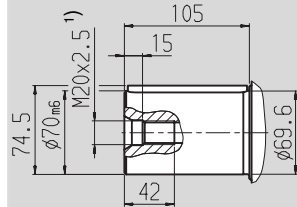

1) DIN 332 center hole

Ports

Port	Description	Standard	Size	Tightening torque, max
A, B	Service line port (high pressure series)	SAE J518,	1 1/2 in	
A ₁ , B ₁	Additional service line ports for plate 15	SAE J518,	1 1/2 in	
	Threaded fitting A/B	DIN 13	M16x2; 24 deep	see safety instructions
T ₁	Leakage-fuel port	DIN 3852	M33x2; 18 deep	540 Nm
T ₂	Leakage fluid/oil drain ²⁾	DIN 3852	M33x2; 18 deep	540 Nm
X, X ₁ , X ₂	Pilot pressure port	DIN 3852	M14x1.5; 12 deep	80 Nm
X ₃	Port for remote control valve	DIN 3852	M14x1.5; 12 deep	80 Nm
P	Connection for charge oil supply	DIN 3852	M14x1.5; 12 deep	80 Nm
G	Port for synchronous control of several units and for remote charge pressure ²⁾	DIN 3852	M18x1.5; 12 deep	140 Nm
G ₂	Port for 2nd pressure setting ²⁾	DIN 3852	M18x1.5; 12 deep	140 Nm
U	Flow port ²⁾	DIN 3852	M18x1.5; 12 deep	140 Nm
M	Measuring port for charge pressure ²⁾	DIN 3852	M14x1.5; 12 deep	80 Nm
M _A , M _B	Measuring ports, operating pressure ²⁾	DIN 3852	M14x1.5; 12 deep	80 Nm
M _{St}	Measuring port for pilot pressure ²⁾	DIN 3852	M14x1.5; 12 deep	80 Nm

²⁾ closed

Unit Dimensions, Size 500

Before finalizing your design, please request approved installation drawing.

Hydraulic control, pilot pressure dependent, with pressure control, direct HD.D, remote control HD.G

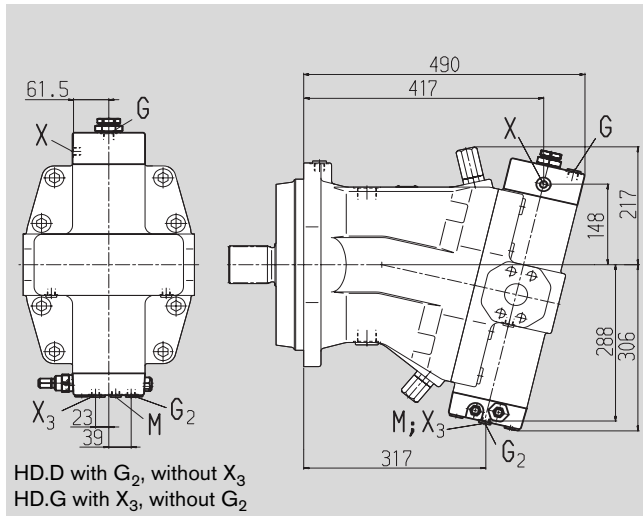

Electrical control with proportioning valve EP1, EP2

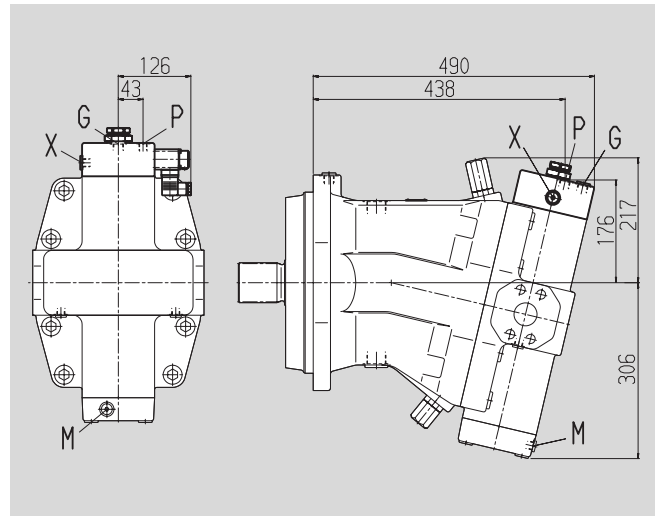

Electrical control (proportioning valve) with pressure control, direct EP.D. remote EP.G

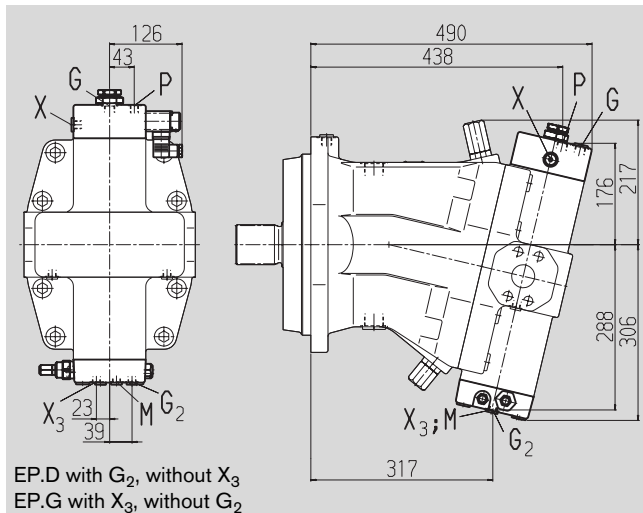

Electrical two-point control with solenoid EZ1, EZ2

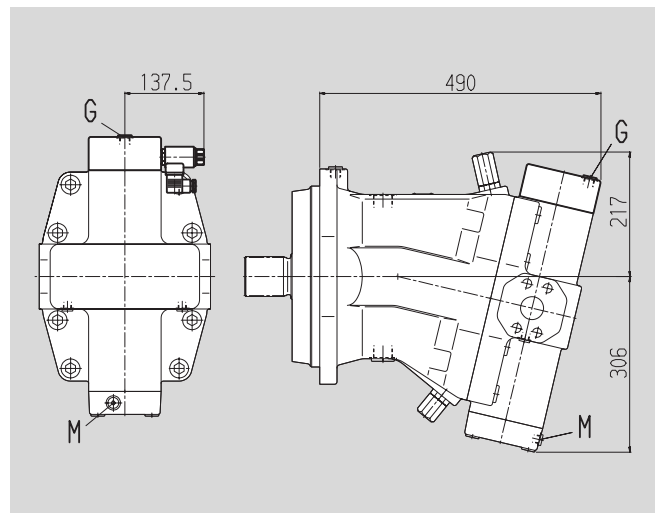

Automatic control, high-pressure dependent HA1, HA2, with hydraulic override HA1T, HA2T

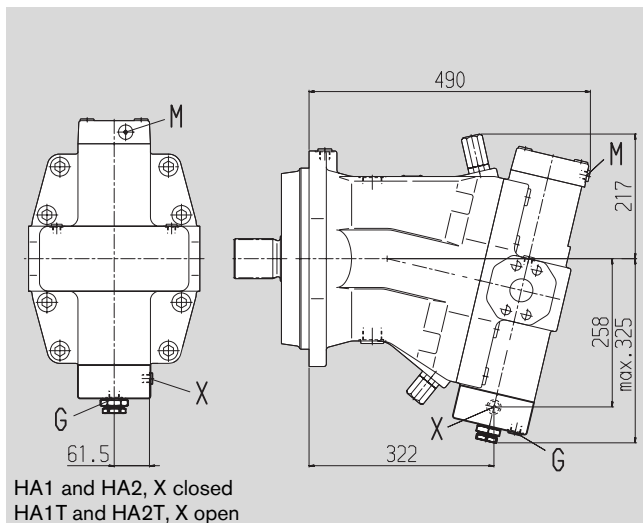

Hydraulic control, speed dependent DA

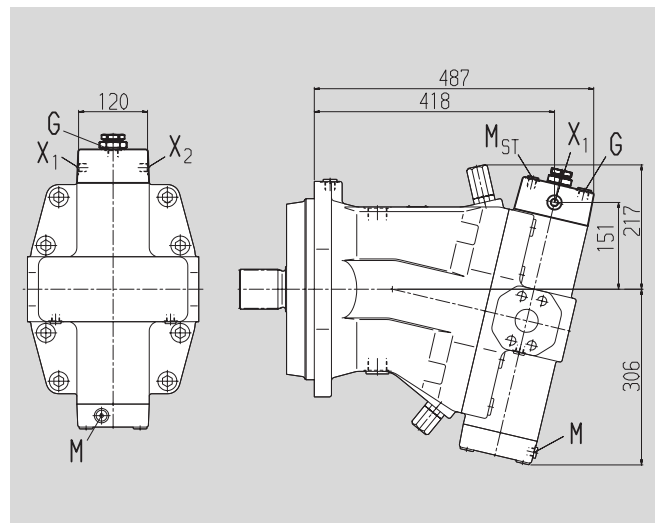

Unit Dimensions, Size 1000

Before finalizing your design, please request approved installation drawing.

Hydraulic control, pilot pressure dependent HD1, HD2, HD3

Hydraulic two-point control HZ

Service line ports A/B lateral, opposite (02), lateral, opposite + at rear (15)

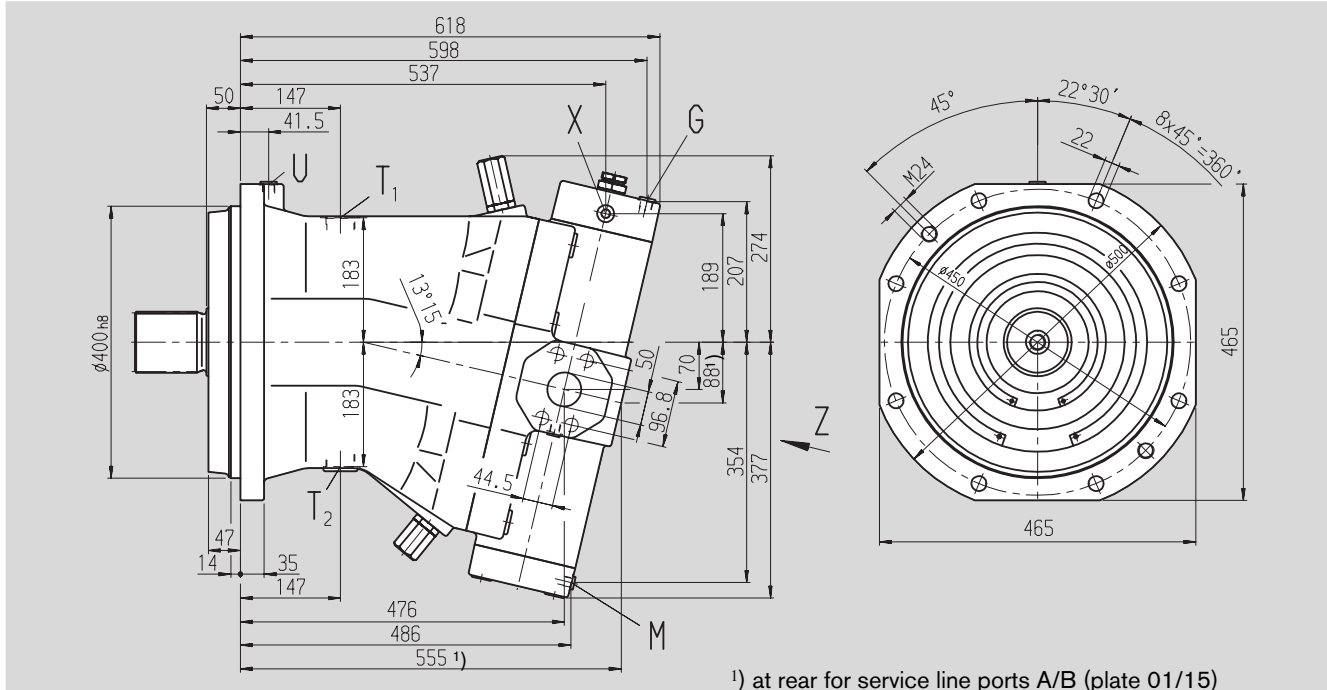

1) at rear for service line ports A/B (plate 01/15)

View Z

Service line ports A/B lateral, opposite (02)

Service line ports A/B at rear (01)

Service line ports A/B / A₁ / B₁ lateral, opposite + at rear (15)

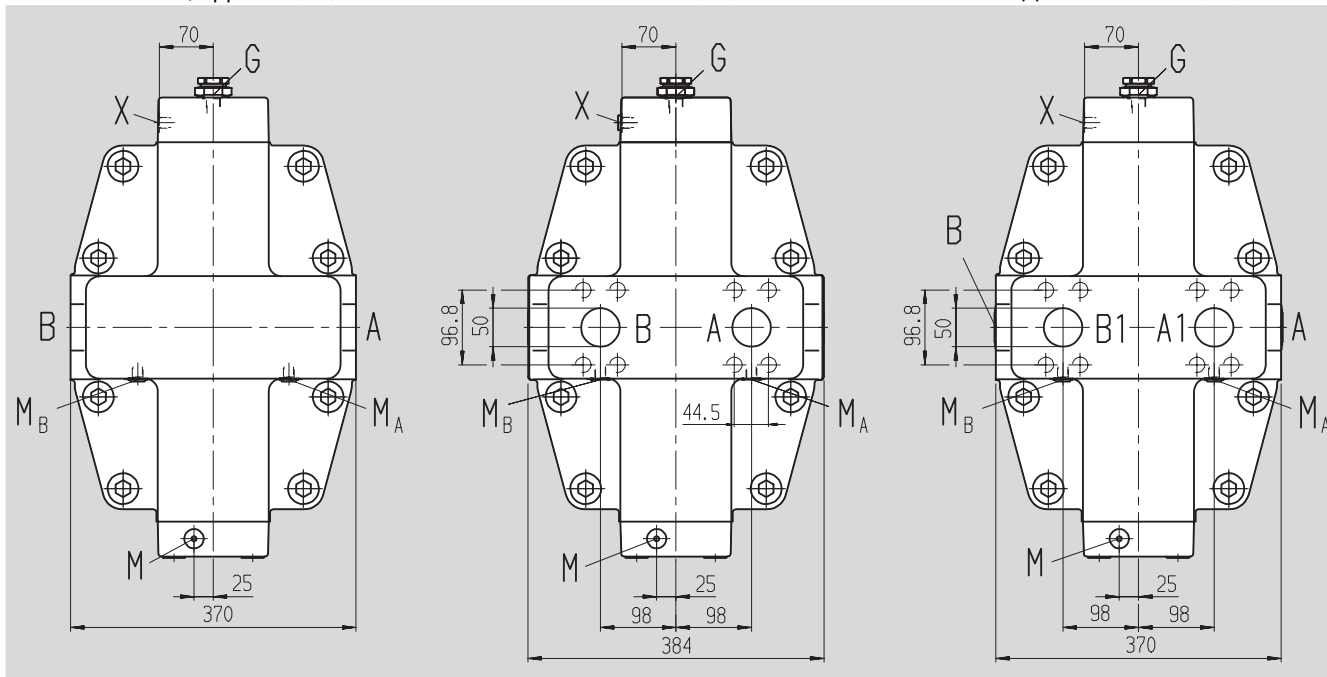

Unit Dimensions, Size 1000

Before finalizing your design, please request approved installation drawing.

Shaft ends

Z Splined shaft
DIN 5480
W90x3x30x28x9g

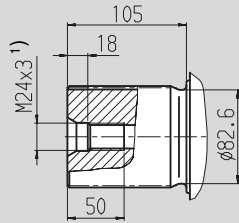

P Cyl. shaft,
with adjusting spring
DIN 5480
AS25x14x125

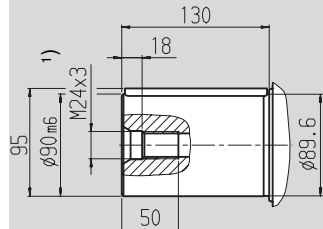

1) DIN 332 center hole

Ports

Port	Description	SAE	Depth	Tightening torque, max
A, B	Service line port (high pressure series)	SAE J518,	2 in	
A ₁ , B ₁	Additional service line ports for plate 15	SAE J518,	1 1/2 in	
	Threaded fitting A/B	DIN 13	M20x2.5; 24 deep	see safety instructions
T ₁	Leakage-fuel port	DIN 3852	M42x2; 20 deep	720 Nm
T ₂	Leakage fluid/oil drain ²⁾	DIN 3852	M42x2; 20 deep	720 Nm
X, X ₁ , X ₂	Pilot pressure port	DIN 3852	M14x1.5; 12 deep	80 Nm
X ₃	Port for remote control valve	DIN 3852	M14x1.5; 12 deep	80 Nm
P	Port for charge oil supply	DIN 3852	M14x1.5; 12 deep	80 Nm
G	Port for synchronous control of several units and for remote charge pressure ²⁾	DIN 3852	M18x1.5; 12 deep	140 Nm
G ₂	Port for 2nd pressure setting ²⁾	DIN 3852	M18x1.5; 12 deep	140 Nm
U	Flow port ²⁾	DIN 3852	M18x1.5; 12 deep	140 Nm
M	Measuring port for charge pressure ²⁾	DIN 3852	M14x1.5; 12 deep	80 Nm
M _A , M _B	Measuring ports, operating pressure ²⁾	DIN 3852	M14x1.5; 12 deep	80 Nm
M _{St}	Measuring port for pilot pressure ²⁾	DIN 3852	M14x1.5; 12 deep	80 Nm

²⁾ closed

Unit Dimensions, Size 1000

Before finalizing your design, please request approved installation drawing.

Hydraulic control, pilot pressure dependent, with pressure control, direct HD.D, remote control HD.G

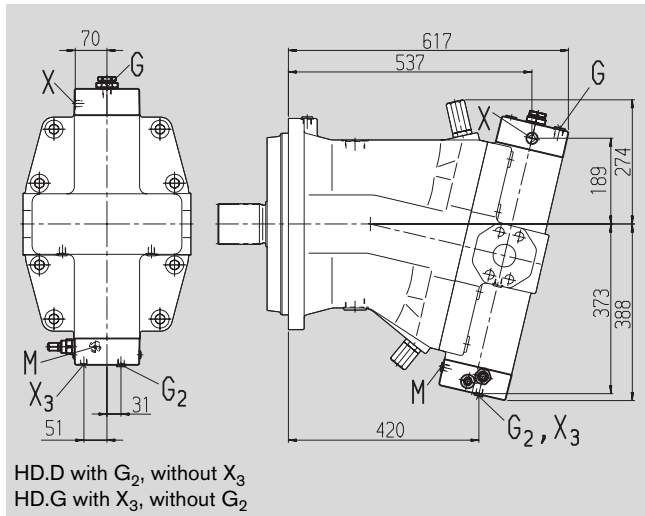

Electrical control with proportioning valve EP1, EP2

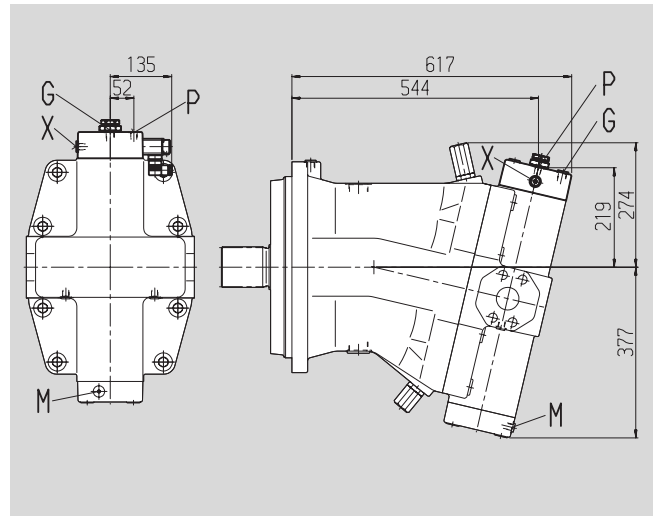

Electrical control (proportioning valve) with pressure control, direct EP.D. remote EP.G

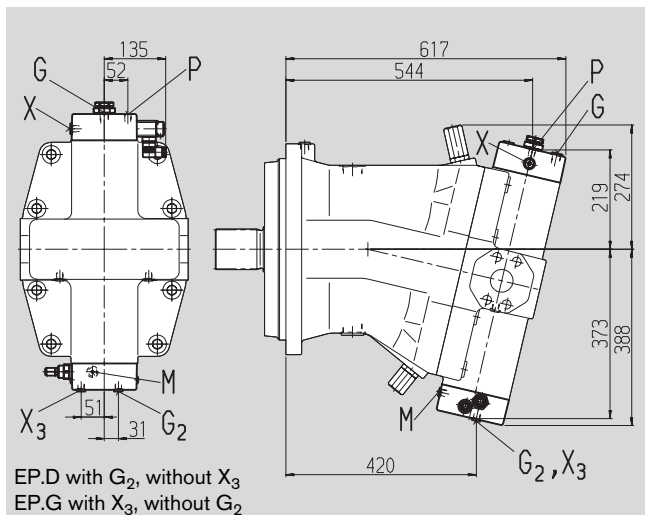

Electrical two-point control with solenoid EZ1, EZ2

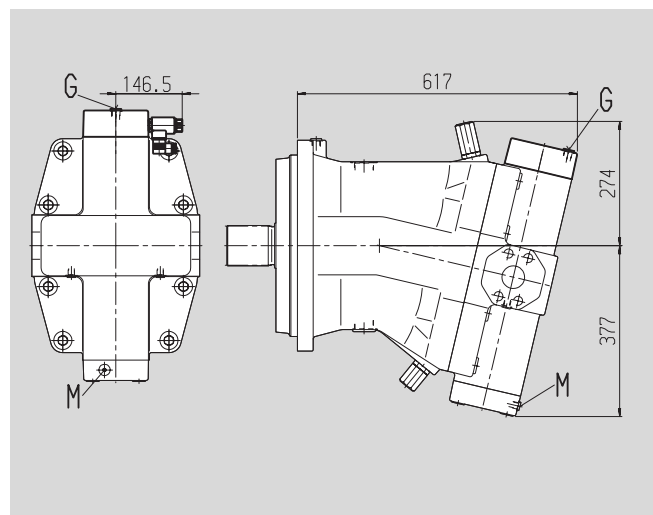

Automatic control, high-pressure dependent HA1, HA2, with hydraulic override HA1T, HA2T

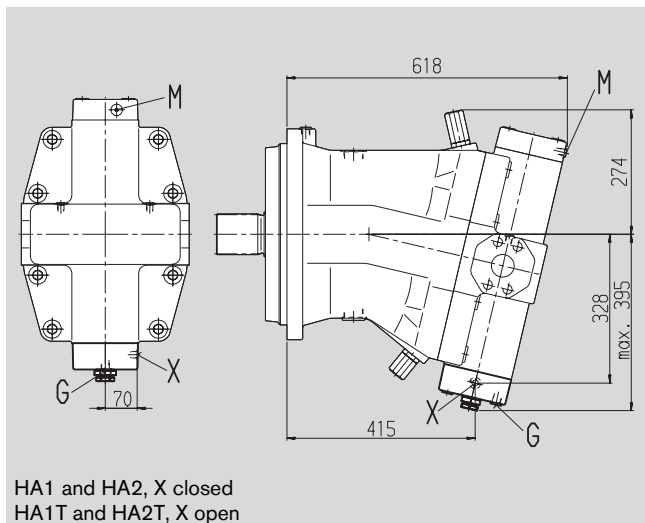

Hydraulic control, speed dependent DA (under development)

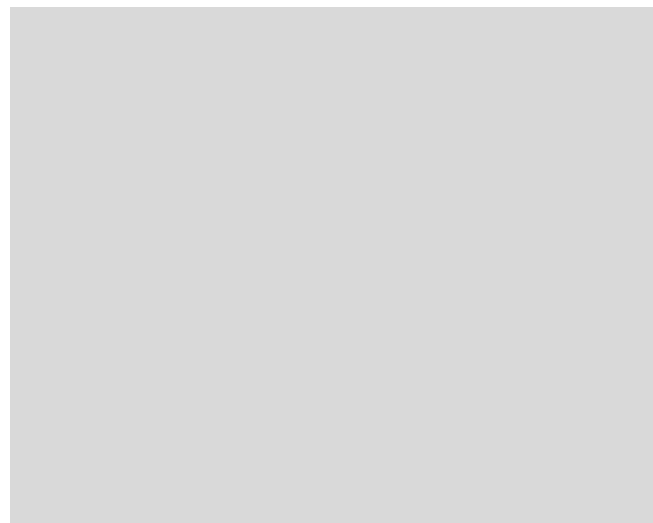

Flushing and Boost Pressure Valve

The flushing and boost pressure valve is used to remove heat from the closed circuit and to ensure that a minimum charge pressure is present (opening pressure 16 bar, fixed; note when setting primary valve). A side effect is flushing of the case.

Warm pressure fluid is removed from the relevant low pressure side into the motor case. This is then fed into the reservoir, together with the leakage fluid. The pressure fluid drawn out of the closed circuit in this way has to be replaced by cooled oil that is pumped in by the charge pump.

In the open circuit, the flushing and boost pressure valve is used solely to flush the case from the return line.

The valve is fitted to the variable displacement motor (or integrated into the servo unit, depending on the type of control and the size).

Restrictors can be used to adjust the flow as required.

Standard flow at low pressure $\Delta p_{ND} = 25$ bar

Size	Quantity	Mat. no. of restrictor
28, 55	3.5 l/min	09651766
80	5 l/min	09419695
107	8 l/min	09419696
140, 160, 200	10 l/min	09419697
250	10 l/min	On request
355-1000	16 l/min	On request

For sizes 28 to 200, restrictors for flows of 3,5 - 10 l/min can be supplied. In the case of non-standard flows, please specify the restrictor you require when placing your order.

Sizes 28 to 200

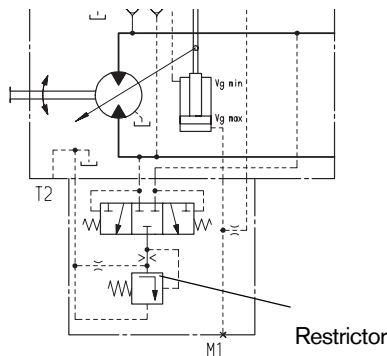

Sizes 250 to 1000

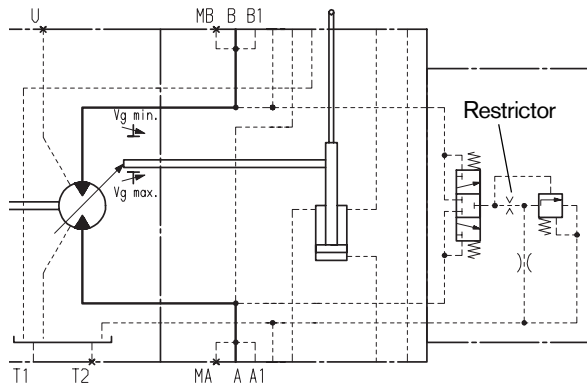

Sizes 28 to 200

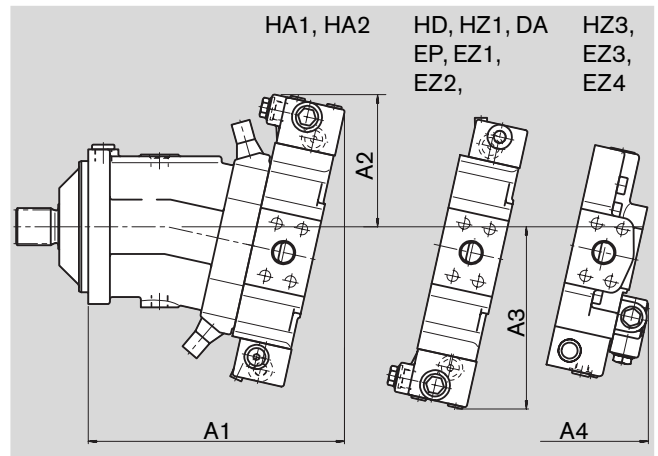

Size	A1	A2	A3	A4
28	214	125	161	—
55	243	133	176	236
80	273	142	193	254
107	288	144	200	269
140	321	154	218	—
160	328	154	220	—
200	345	160	231	—

Sizes 250 to 1000

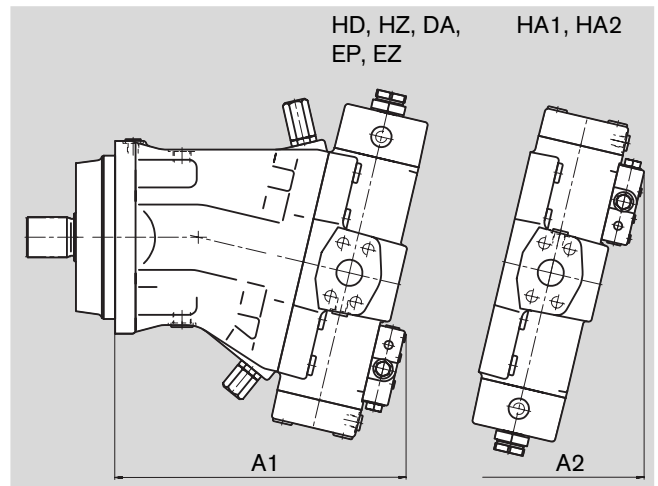

Size	A1	A2
250	357	402
355	397	446
500	440	504
1000	552	629

Counterbalance Valve BVD (sizes 55 to 160)

Function

Driving/winch counterbalance valves prevent the motor speeding up out of control during descents/load reduction and consequently cavitation of axial piston motors operating in an open circuit. Cavitation occurs in axial piston motors as soon as the speed from the drive element on the outside exceeds the speed governed by the incoming flow volume.

Please note

- BVD counterbalance valve must be specified explicitly in the order. We recommend ordering the counterbalance valve and the motor as a set. Ordering example: A6VM80HA1T/63W-VAB380A + BVD20F27S/41B-V03K16D0400S12
- For safety reasons, winch drive are forbidden with start of control at $V_{g \min}$ (e.g. HA)!
- The counterbalance valve does not replace the mechanical service brake and parking brake.
- Note the detailed information about the BVD counterbalance valve contained in RE 95522

Driving counterbalance valve BVD..F

Version with start of control at $V_{g \min}$ (standard for HA).

Winch counterbalance valve BVD..W

Version with start of control at $V_{g \min}$ (standard for HD, EP).

Example of application

- Transmission on wheeled excavators

Typical applications

- Winch gears in cranes
- Slew gears in excavator crawlers

Example circuit diagram for transmission on wheeled excavators

A6VM80HA1T/63W-VAB380A + BVD20F27S/41B-V03K16D0400S12

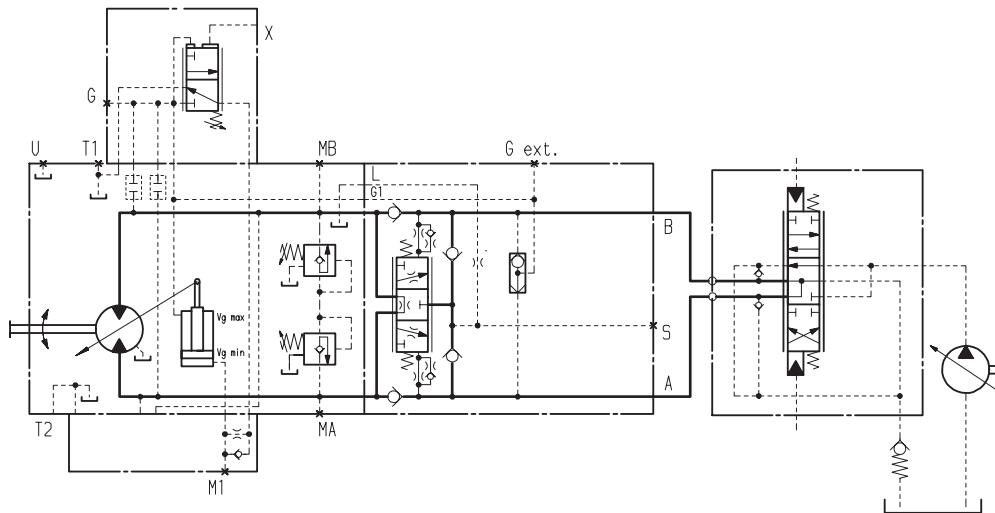

Example circuit diagram for winch gears in cranes

A6VM80HD1D/63W-VAB380B + BVD20W27L/41B-V01K00D0600S00

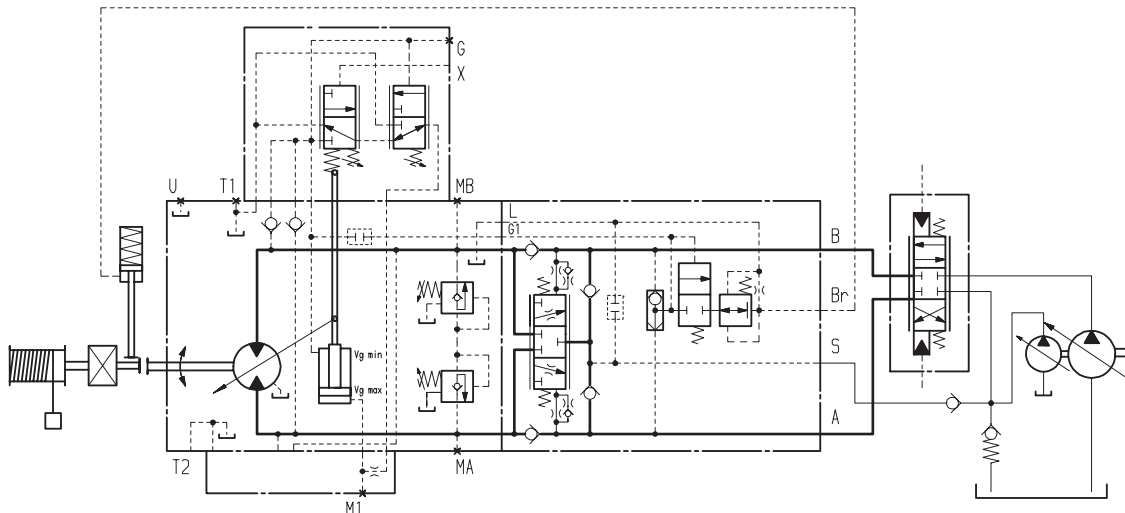

Counterbalance Valve BVD (sizes 55 to 160)

Before finalizing your design, please request approved installation drawing.

Unit dimensions

A6VM to HA

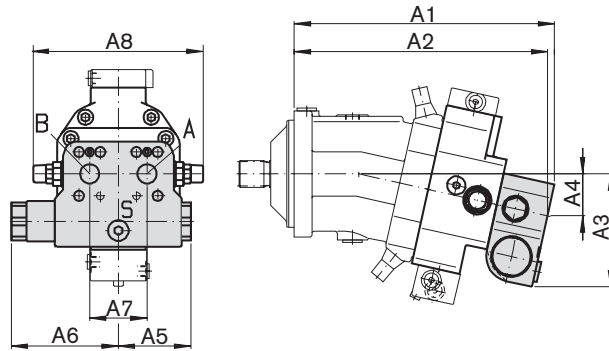

A6VM to HD and A6VM to EP

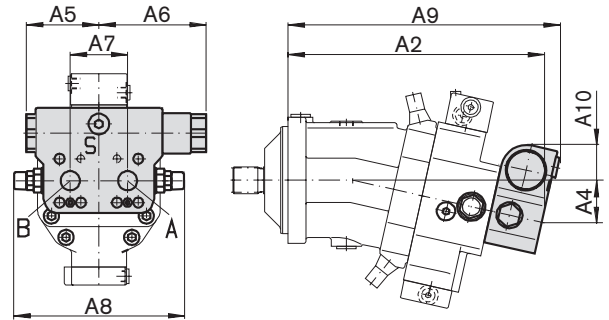

A6VM	Counterbalance valve			Dimensions									
Size...Plate	Type	Conn. A, B	Conn. S	A1	A2	A3	A4	A5	A6	A7	A8	A9	A10
55...38	BVD20...17	3/4 in	M22x1.5;14 deep	311	302	143	50	98	139	75	222	326	50
80...38	BVD20...27	1 in	M22x1.5;14 deep	340	331	148	55	98	139	75	222	355	46
107...37	BVD20...28	1 in	M22x1.5;14 deep	362	353	152	59	98	139	84	234	377	41
107...38	BVD25...38	1 1/4 in	M27x2; 16 deep	380	370	165	63	120.5	175	84	238	395	56
140...38	BVD25...38	1 1/4 in	M27x2; 16 deep	411	401	168	67	120.5	175	84	238	446	53
160...38	BVD25...38	1 1/4 in	M27x2; 16 deep	417	407	170	68	120.5	175	84	238	432	51
250...08	On request												

Fastening the counterbalance valve

When delivered, the counterbalance valve is fastened to the motor by 2 tacking bolts. Do not remove the tacking bolts when attaching the working lines. If the counterbalance valve and motor are delivered separately, the counterbalance valve must first be fastened to the motor port plate using the tacking bolts provided. In both cases, the final fastening of the counterbalance valve to the motor is done using the threaded connection of the working lines, e.g. using SAE flanges. A total of 6 bolts with thread lengths B1+B2+B3 and 2 bolts with thread lengths B3+B4 will be required.

When tightening the bolts, it is vital that the sequence (1 to 8) as shown in the diagram is adhered to and carried out in two phases.

In the first phase the bolts should be tightened to 50% of their tightening torque before being tightened to maximum tightening torque in a second phase (see table below).

Thread	Property class	Tightening torque in Nm
M10	10.9	75
M12	10.9	130
M14	10.9	205

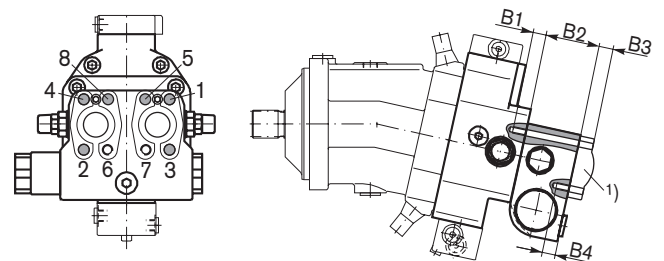

1) Flange, e.g. SAE flange

Size...Plate	55...38	80...38 107...37	107. 140. 160...38
B1 ²⁾	M10x1.5 17 deep	M12x1.75 15 deep	M14x2 19 deep
B2	68	68	85
B3	customer-specific		
B4	M10x1.5 15 deep	M12x1.75 16 deep	M14x2 19 deep

²⁾ minimum reach required 1 x Ø

Speed Measurement (sizes 28 to 200)

The A6VM...D and A6VM...F ("prepared for speed measurement") versions have serrations on the transmission. The rotating, serrated transmission generates a signal in proportion to the speed. The signal is picked up by a sensor and forwarded for evaluation.

The sensor is screwed into (inductive speed sensor ID) or flanged onto (Hall effect speed sensor HDD) the upper leakage-fuel port T₁ (sizes 28 to 200). The spacer (sizes 28 to 107) or thread reducing adapter (sizes 140 to 200) required for the inductive speed sensor is supplied with the sensor.

The speed measurement sensor can be ordered with the motor (sizes 28 to 200).

Suitable sensors:

- Inductive speed sensor ID (see RE 95130) version "D"
- Hall-effect speed sensor HDD (see RE 95135) version "F"

On units employing speed measurement, port T₂ must be used to drain the leakage fuel (sizes 28 to 200).

A6VM 28...200 EP

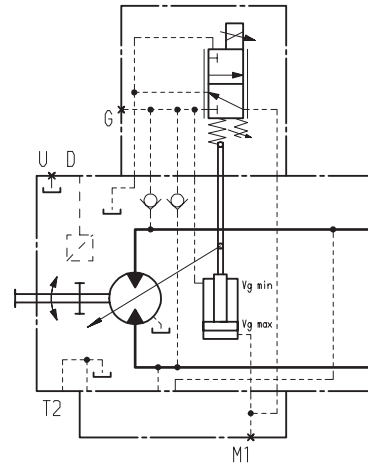

Hall-effect speed sensor HDD

Sizes 28 to 200

Inductive speed sensor ID

Sizes 28 to 200

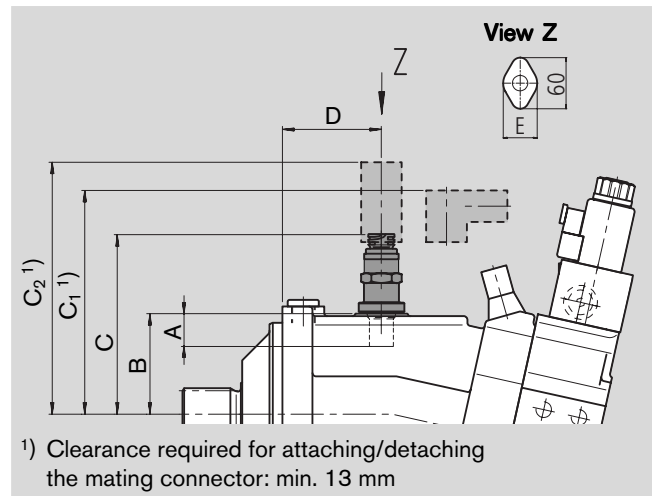
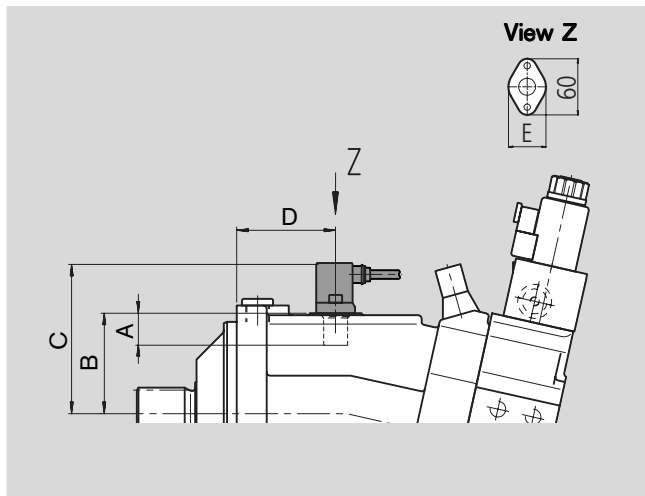

Size		28	55	80	107	140	160	200
Sensor selection		IDR 18/20 - L250				IDR 18/20 - L400		
	Type designation	HDD.L16../20						
Number of teeth		40	54	58	67	72	75	80
HDD	A Insertion depth (tolerance ± 0.1)	16	16	16	16	16	16	16
	B Contact surface	58.6	72.6	76.6	85.6	90.6	93.6	98.6
	C	97	111	115	124	129	132	137
ID:	A Insertion depth (tolerance ± 0.1)	17.5	17.5	17.5	17.5	24.5	24.5	24.5
	B Contact surface	60	74	78	87	99	102	107
	C without mating connector	120	134	138	147	157	160	165
	C ₁ with 90° mating connector	175	189	193	202	212	215	220
	C ₂ with 180° mating connector	153.5	167.5	171.5	180.5	190.5	193.5	198.5
D (mm)	58	67	76	78	92	92,5	96	
E (mm)		32	40	40	40	42	45	45

Swivel Angle Indicator (sizes 250 to 1000)

Before finalizing your design, please request approved installation drawing.

Optical swivel angle indicator (V)

The swivel position is indicated by a pin on the side of the port plate. The length of pin protruding out of the plate depends on the position of the control lens.

If it lies flush with the port plate, the motor is at start of control. At maximum swivel, the pin is 8 mm long (visible after removing the cap nut).

Sizes 250 to 1000

Example: Start of control at $V_{g \max}$

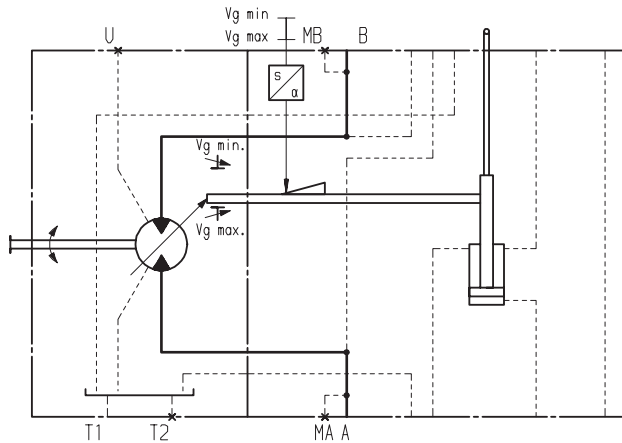

Electrical swivel angle indicator (E)

The position of the motor is signaled by an inductive position sensor. It converts the travel of the control device into an electrical signal.

The swivel position can be transmitted to an electrical control unit by means of this signal.

Inductive position sensor, model IW9-03-01

Sizes 250 to 1000

Example: Start of control at $V_{g \min}$

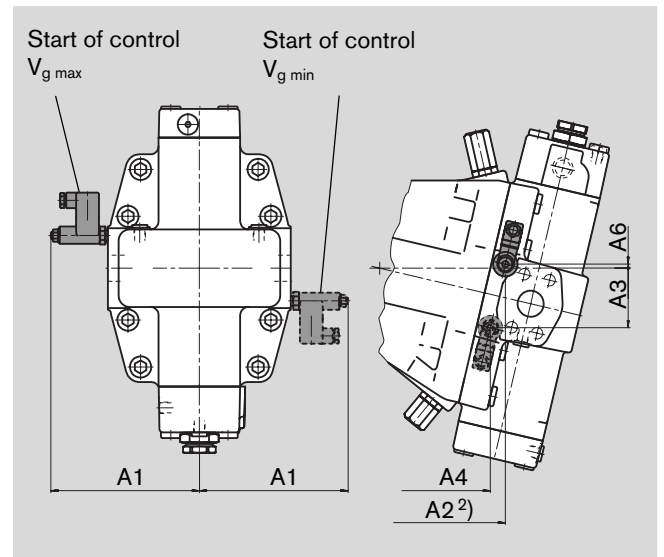
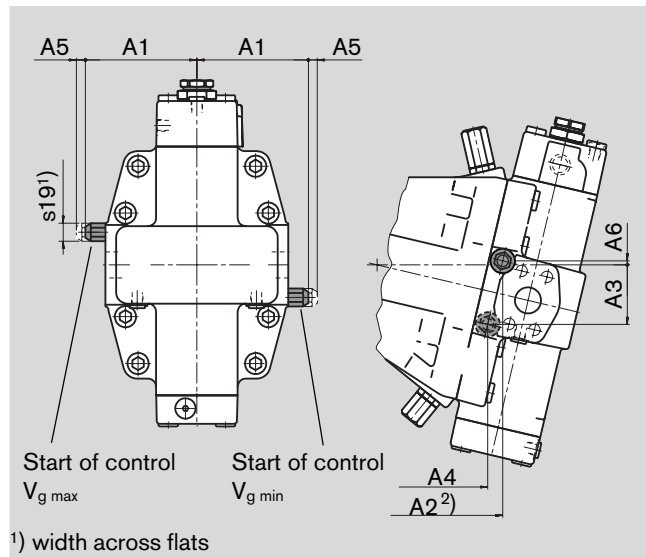
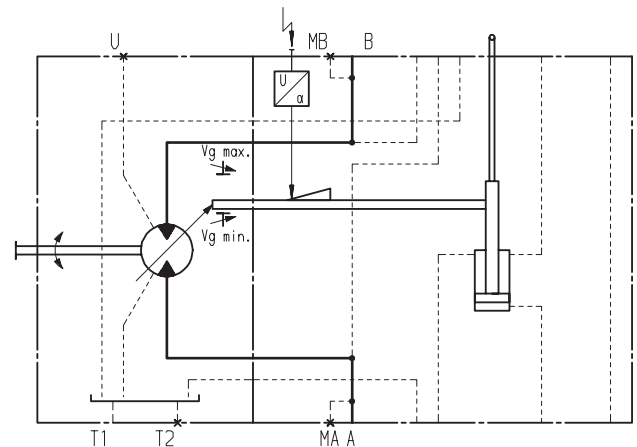

Size	A1	A2 ²⁾	A3	A4	A5 ³⁾	A6
250	136.5	256	73	238	11	5
355	159.5	288	84	266	11	8
500	172.5	331	89	309	11	3
1000	208.5	430	114	402	11	3

Size	A1	A2 ²⁾	A3	A4	A6
250	182	256	73	238	5
355	205	288	84	266	8
500	218	331	89	309	3
1000	254	430	114	402	3

²⁾ Distance to mounting flange

³⁾ Clearance required for removing cap nut

Connectors for Solenoids (for EP, EZ, HA.U, HA.R, DA only)

DEUTSCH DT04-2P-EP04, 2-pin

injection molded, without bidirectional quenching diode (for EP, EZ1/2, DA) _____ **P**

injection molded, with bidirectional quenching diode (for EZ1/2, DA) _____ **Q**

with lead, without bidirectional quenching diode (for EP, EZ, HA.U, HA.R, DA; not for new projects) _____ **T**

Degree of protection to DIN/EN 60529: IP67 and IP69K

The Q version with a bidirectional quenching diode is only available as an option for solenoids for the EZ1/2, DA-controls.

The protection circuit with a bidirectional quenching diode is required to limit overvoltages. Overvoltages are generated by disconnecting the current using switches, relay contacts or by unplugging an energized mating connector.

Switch symbol

without bidirectional quenching diode

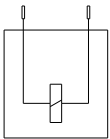

with bidirectional quenching diode

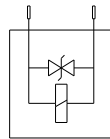

Mating connector

Female connector DEUTSCH DT06-2S-EP04
Rexroth Mat. no. 02601804

comprising:	DT designation
- 1 case _____	DT06-2S-EP04
- 1 wedge _____	W2S
- 2 sockets _____	0462-201-16141

The female connector is not part of the scope of supply. It can be supplied by Rexroth on request.

Hirschmann DIN EN 175 301-803-A/ISO 4400

(not for new projects using sizes 28 to 200)

without bidirectional quenching diode (for EP, EZ, HA.U, HA.R, DA) _____ **H**

Degree of protection to DIN/EN 60529: IP65

The sealing ring in the cable gland (M16x1.5) is suitable for cables 4.5 mm to 10 mm in diameter.

The female connector is part of the scope of supply of the motor.

DEUTSCH DT04-2P-EP04, 2-pin

injection molded, without/with bidirectional quenching diode _ P, Q

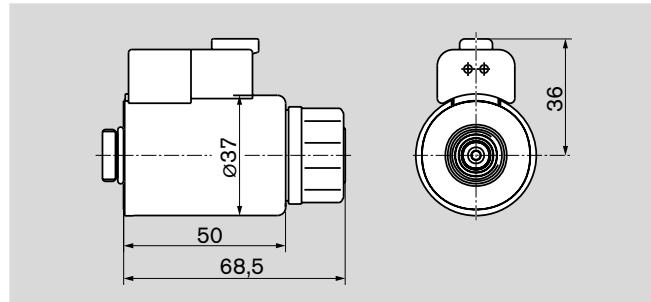

DEUTSCH DT04-2P-EP04, 2-pin

with lead, without bidirectional quenching diode _____ **T**

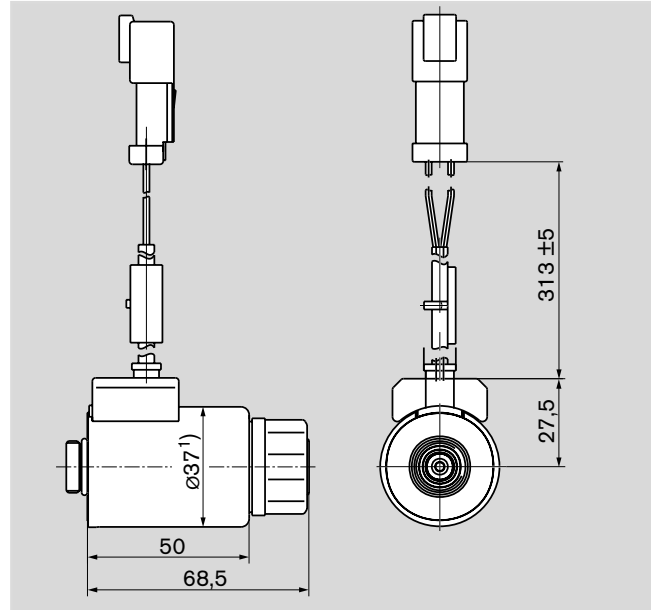

1) Solenoid with ø45 for following controls:
HA.U, HA.R (for elec. override), EZ3 and EZ4.
Degree of protection to DIN EN 60529: IP65

Hirschmann DIN EN 175 301-803-A/ISO 4400

without bidirectional quenching diode _____ **H**

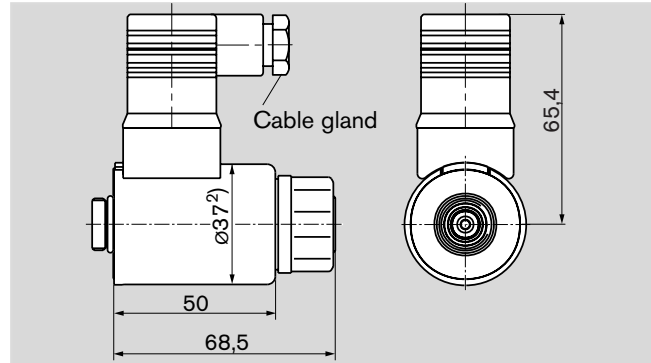

2) Solenoid with ø45 for following controls:
HA.U, HA.R (for elec. override), EZ3 and EZ4.
Not for new projects.

Installation and Startup Instructions

General

The motor case must be completely filled up with hydraulic fluid during startup and during operation (filling the case chamber). The motor must be started up at low speed and no load until the system has been bled completely.

If stopped for an extended period, fluid may drain out of the case through the working lines. When restarting, make sure that the case contains sufficient fluid.

The leakage fluid inside the case chamber must be drained off to the reservoir through the highest leakage-fuel port.

The motor is designed to operate in any position.

Installation below the reservoir

Motor below minimum oil level in reservoir (standard)

- Fill axial piston motor before startup via the highest leakage-fuel port
- Run the motor at low speed until the system is bled completely (bleed through service line port A, B if tubing is long)
- Minimum immersion depth of leakage line in reservoir: 200 mm (relative to the min. oil level in the reservoir)
- Additional measures required for installation position 2 (shaft facing up)

With installation position 2, make sure that the motor case is completely full before starting up. In this installation position the system must be bled via U. An air cushion in the vicinity of the bearing will damage the axial piston unit.

- Bleed the A6VM variable displacement motor in a closed circuit:
 - via port G
 - no bleeding required if flushing valve fitted

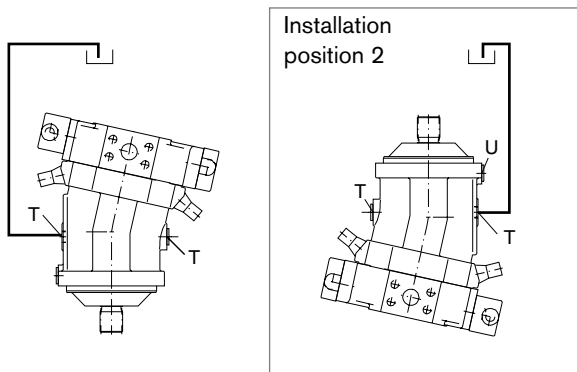
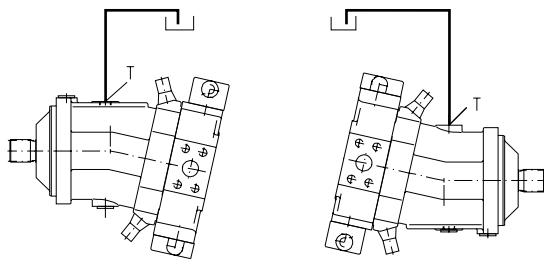

Installation above the reservoir

Motor above minimum oil level in reservoir

- Proceed in same way as below the reservoir installation
- Additional measures for installation positions 1 and 2

If stopped for an extended period, fluid may drain out of the case chamber through the working lines (air enters through the shaft seal). The bearings will therefore not be properly lubricated when the motor is started up again. Fill the axial piston unit before restarting via the highest leakage-fuel port. In installation position 2 the system must be bled via U.

- Additional measures required for installation position 2 (shaft facing up)

In this installation position the bearings will not be properly lubricated, even if there is still some fluid in the case chamber. Putting a non-return valve (opening pressure 0.5 bar) in the leakage line can prevent the system emptying through the line.

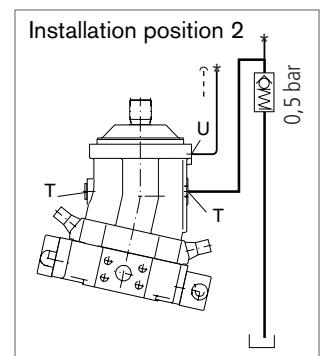
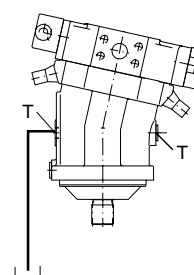
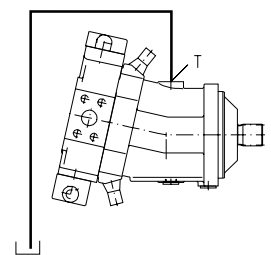
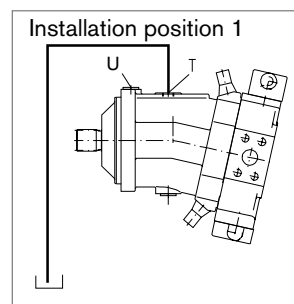

Safety Instructions

- The A6VM motor is designed to be used in open and closed circuits.
- Project planning, assembly, and startup of the motor require the involvement of trained personnel.
- The working and functional ports are only designed to accommodate hydraulic piping.
- Tightening torques: Observe the maximum permitted tightening torques of the various fittings (manufacturer's figures)!
For DIN 13 mounting bolts, we recommend that tightening torques be checked on a case by case basis in accordance with VDI 2230, published 2003.
- There is a danger of burning while the motor is running and for a short time afterwards.
- The data and information contained herein must be adhered to.

Bosch Rexroth AG
Mobile Hydraulics
Produktbereich Axialkolbenmaschinen
Werk Elchingen
Glockeraustraße 2
89275 Elchingen, Germany
Tel: +49 (0) 73 08 82-0
Fax: +49 (0) 73 08 72 74
info.brm-ak@boschrexroth.de
www.boschrexroth.com/axial-piston-motors

Werk Horb
An den Kelterwiesen 14
72160 Horb, Germany
Tel: +49 (0) 74 51 92-0
Fax: +49 (0) 74 51 82 21

© 2003 by Bosch Rexroth AG, Mobile Hydraulics, 89275 Elchingen
All rights reserved. Neither this document nor any part of it may be reproduced or stored, processed, duplicated or circulated e. g. by using electronic systems in any form or by any means without the prior authorisation of Bosch Rexroth AG. In case of infringements the infringing party will be obliged to compensate for all damages incurred.

The data specified in this brochure (data sheet) is intended to describe the products. No warranty or statement, whether express or implied with regard to fitness for particular purposes or merchantability may be derived from our information (data sheet). The information provided in this brochure (data sheet) does not release the user from any of its obligations of own judgement and verification for the specific purposes. Please note that our products are subject to a natural process of wear and tear and aging.